

CATALOGUE

COMPRESSORS

Breathing air



High pressure compressors
for breathing air and technical gases

**We build quality.
Made in Italy.**



A profoundly Italian company, Coltri began building high-pressure scuba diving compressors in 1963.

The company soon expanded into other fields, including firefighting compressors and industrial gas compressors. Today we are once again looking in a new direction.

Ongoing advances in design and manufacture are at the very core of our identity: more than fifty years of continuous development have enabled us to engineer equipment that now sets the benchmark for the industry worldwide.

Our commitment to research and development has enabled us to shift from consuming the latest technology to becoming key players ourselves in advancing technology in the industry. We use all the latest tools, such as robots and digitally controlled machining centers, to manufacture increasingly reliable, efficient and durable products.

Every component in our pump units was designed and engineered in Coltri's workshops and is the result of careful research and extensive testing. We assemble all our compressors in their entirety within our company according to rigorous quality standards. Exceptionally high-precision machinery, such as ZEISS® tools, play a key role in dimensional metrology. This enables us to determine the geometric characteristics of our components and accurately gauge how they will perform when used in more complex units.

Our focus and constant growth, steered by standards of excellence, have earned us internationally recognized certifications of quality that reflect our dedication and commitment.

We like to think of ourselves as facilitators. We build our machines to make it simpler to take on challenges, overcome limits and imagine new possibilities. Whether it's for a hobby, an industrial application or an emergency response service, Coltri Compressors is there to raise the bar higher, to help you reach uncharted territory.



Discover our construction quality.

Scan the QR code to watch the video.

Application

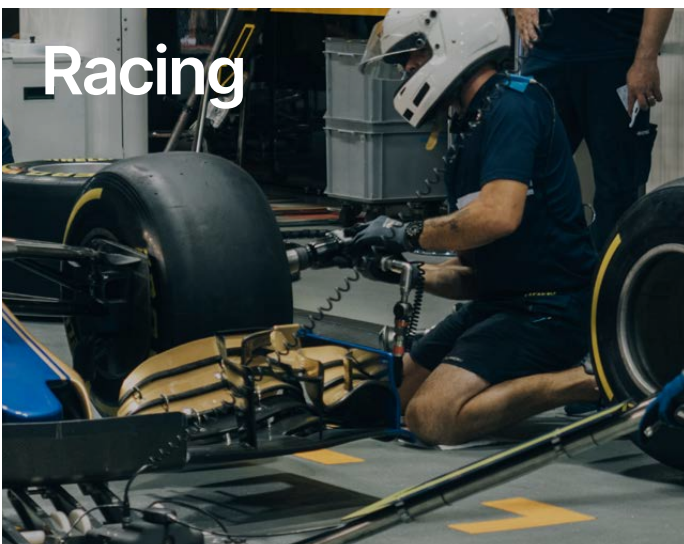

Research, development, production and assembly take place in the 8,000 square meters of the headquarters thanks to our human value.

From Desenzano del Garda, the Company is a byword for Made In Italy quality, reaching 130 countries around the world every day. Research, development, production and assembly in our 8000 m² plant revolve around the "Coltri human value": over 50 technicians committed to overcoming new challenges in performance, silence, durability, and innovation. To meet these challenges, the company uses the most advanced instruments, including robots and numerically

controlled machine tools, to create products that are ever more reliable, efficient and effective. To ensure our after-sales service is on a par with our product line, customers can avail of our a spare parts warehouse for ordinary and extraordinary maintenance, and courtesy compressors to cover any contingency.

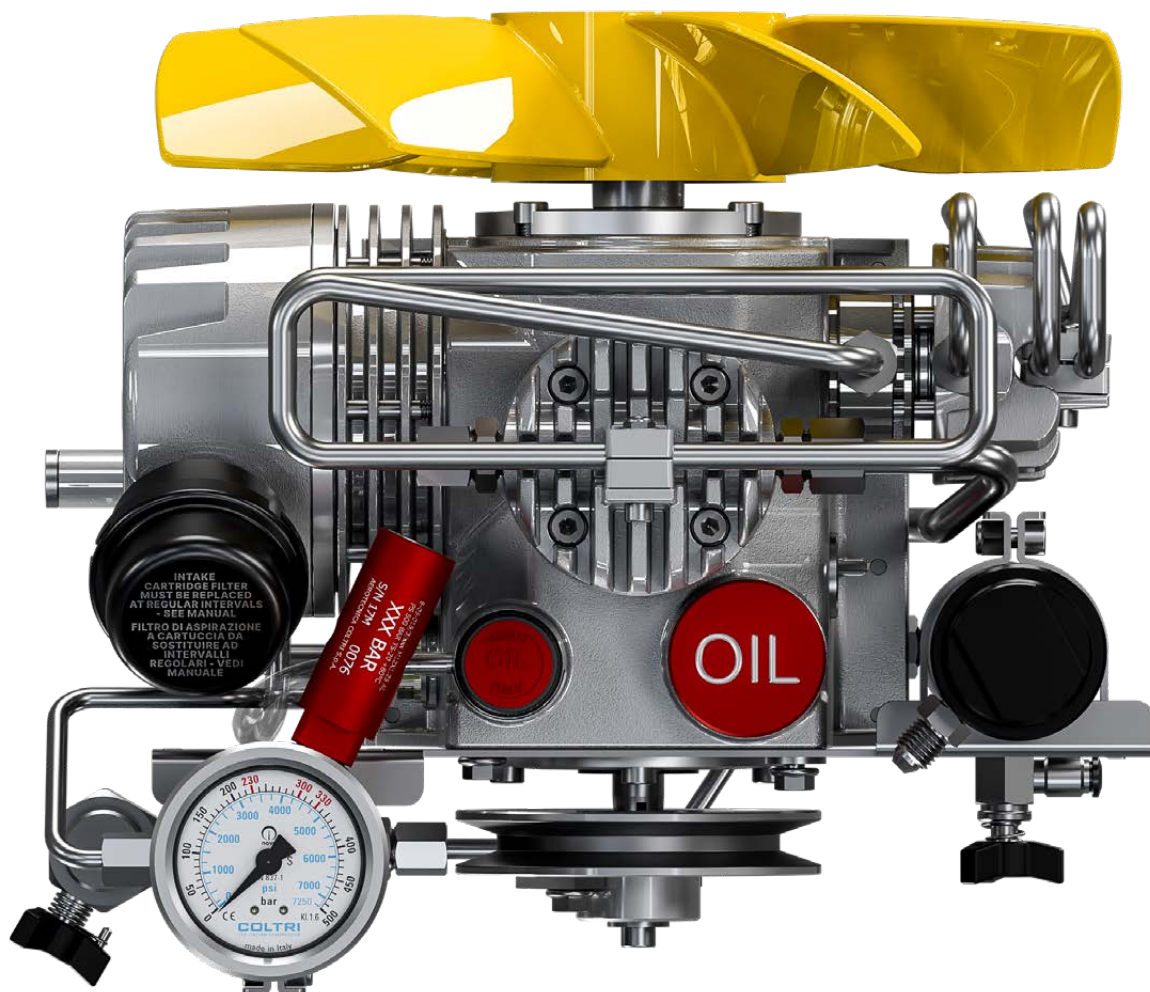

Portables line

Icon LSE

Electric



Icon LSE 50 EM

Icon LSE 100 EM

Icon LSE 100 ET

Charging rate

50 l/min

100 l/min

100 l/min

Filling time¹

60 min

20 min

20 min

Engine power

1,1 kW

Single-phase electric

2,2 kW

Single-phase electric

3 kW

Three-phase electric

¹ Filling time 10 l empty cylinder - 0/200 bar (tolerance ±5%)

A great little portable.

The **ICON LSE** series are the world's most widely used portable compressors. Due to their small size and light weight, the models are perfect for a wide range of needs: high-pressure breathing air for diving, recreation, fire fighting and paintball facilities. The models are available with petrol or electric motors, both three-phase and single-phase, and are equipped with the MCH 6 pumping unit. Standard equipment includes a hose fill port with operating pressures from 232 to 330 bar. The user experience is highly customizable with the various options available such as pressure maintenance valve, automatic condensate drain and autostop.

Working pressure from 232 to 330 bar

Standard equipment

- | | | | |
|---|--|---|--|
| 1 | 1 filling connection to choose between
(1a) DIN 232, (1b) DIN 300, (1c) INT/YOKE 232 bar | 3 | Hour meter
Only for single-phase electric motor |
| 2 | 1 filling hose of 1.2 m length | 4 | Frame color Black RAL 9005 |



Optional

- | | | | |
|---|---|----|--|
| 1 | Autostop | 10 | DIN/INT adapter |
| 2 | Automatic condensate drain with timer
Only for single-phase electric motor | 11 | Filling connection DRV/INT |
| 3 | C-Monitor | 12 | Filling hose. Available: 2 m - 3 m |
| 4 | Remote suction hose kit | | Dual output kit 232 bar |
| 5 | Pressure maintaining valve | 13 | Double outlet T fitting for hoses + 2 filling hoses 1,20 m +
2 filling connection DRV DIN 232 bar |
| 6 | Filling connection DRV DIN 232 bar | | Dual output kit 300 bar |
| 7 | Filling connection DRV DIN 300 bar | 14 | Double outlet T fitting for hoses + 2 filling hoses 1,20 m +
2 filling connection DRV DIN 300 bar |
| 8 | Filling connection with gauge DRV DIN 232 bar | | |
| 9 | Filling connection with gauge DRV DIN 300 bar | | |



Dimensions

Width 61 cm (24")
 Depth 37 cm (14.5")
 Height 39 cm (15.3")

Dry weight

ICON LSE 50 EM
 39,5 kg (87 lb)
ICON LSE 100 EM
 39,5 kg (87 lb)
ICON LSE 100 ET
 39 kg (85 lb)



Machine parts

- | | | | | | |
|---|----------------|----|------------------------|----|----------------------|
| 1 | Frame | 6 | Air filter | 11 | Purification system |
| 2 | Pressure gauge | 7 | Fan/belt shroud | 12 | Condensate separator |
| 3 | Electric motor | 8 | Anti-vibration devices | 13 | Safety valve |
| 4 | Pumping unit | 9 | Cooling fan | 14 | Condensate discharge |
| 5 | Oil filler cap | 10 | Belt | | |

Portables line

Icon LSE

Stainless steel

Electric



Icon LSE stainless steel
50 EM

Icon LSE stainless steel
100 EM

Icon LSE stainless steel
100 ET

Charging rate

50 l/min

100 l/min

100 l/min

Filling time¹

60 min

20 min

20 min

Engine power

1,1 kW
Single-phase electric

2,2 kW
Single-phase electric

3 kW
Three-phase electric

¹ Filling time 10 l empty cylinder - 0/200 bar (tolerance ±5%)

A great little portable.

The **ICON LSE Stainless steel** series are the world's most widely used portable compressors. Due to their small size and light weight, the models are perfect for a wide range of needs: high-pressure breathing air for diving, recreation, fire fighting and paintball facilities. The models are available with petrol or electric motors, both three-phase and single-phase, and are equipped with the MCH 6 pumping unit. Standard equipment includes a hose fill port with operating pressures from 232 to 330 bar. The user experience is highly customizable with the various options available such as pressure maintenance valve, automatic condensate drain and autostop.

Working pressure from 232 to 330 bar

Standard equipment

- | | | | |
|---|--|---|--|
| 1 | 1 filling connection to choose between
(1a) DIN 232, (1b) DIN 300, (1c) INT/YOKE 232 bar | 3 | Hour meter
Only for single-phase electric motor |
| 2 | 1 filling hose of 1.2 m length | 4 | Stainless steel frame |



Optional

- | | | | |
|---|---|----|--|
| 1 | Autostop | 10 | DIN/INT adapter |
| 2 | Automatic condensate drain with timer
Only for single-phase electric motor | 11 | Filling connection DRV/INT |
| 3 | C-Monitor | 12 | Filling hose. Available: 2 m - 3 m |
| 4 | Remote suction hose kit | | Dual output kit 232 bar |
| 5 | Pressure maintaining valve | 13 | Double outlet T fitting for hoses + 2 filling hoses 1,20 m +
2 filling connection DRV DIN 232 bar |
| 6 | Filling connection DRV DIN 232 bar | | Dual output kit 300 bar |
| 7 | Filling connection DRV DIN 300 bar | 14 | Double outlet T fitting for hoses + 2 filling hoses 1,20 m +
2 filling connection DRV DIN 300 bar |
| 8 | Filling connection with gauge DRV DIN 232 bar | | |
| 9 | Filling connection with gauge DRV DIN 300 bar | | |



Dimensions

Width 61 cm (24")

Depth 37 cm (14.5")

Height 39 cm (15.3")

Dry weight

ICON LSE Stainless steel 50 EM

39,5 kg (87 lb)

ICON LSE Stainless steel 100 EM

39,5 kg (87 lb)

ICON LSE Stainless steel 100 ET

39 kg (85 lb)

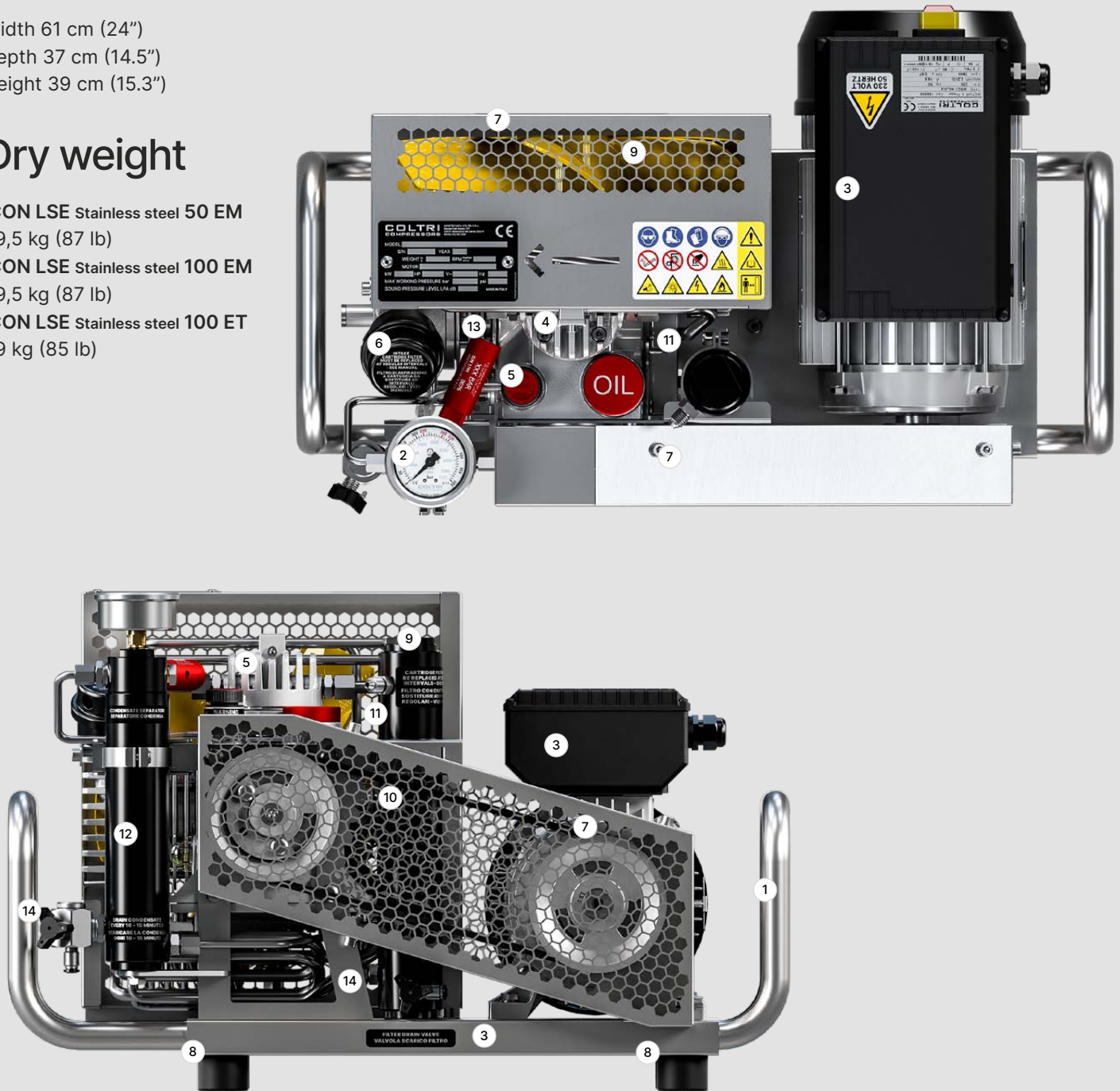

Machine parts

- | | | | | | |
|---|----------------|----|------------------------|----|----------------------|
| 1 | Frame | 6 | Air filter | 11 | Purification system |
| 2 | Pressure gauge | 7 | Fan/belt shroud | 12 | Condensate separator |
| 3 | Electric motor | 8 | Anti-vibration devices | 13 | Safety valve |
| 4 | Pumping unit | 9 | Cooling fan | 14 | Condensate discharge |
| 5 | Oil filler cap | 10 | Belt | | |

Portables line

Icon

Petrol



Icon 100 SH

Icon 100 SK

Charging rate

100 l/min

100 l/min

Filling time¹

20 min

20 min

Engine power

4,3 kW

Petrol HONDA GP 200

4,1 kW

Petrol Kohler SH 265

¹ Filling time 10 l empty cylinder - 0/200 bar (tolerance ±5%)

Dedicated to the most extreme journeys.

	Icon 100 SH Petrol HONDA GP 200	Icon 100 SK Petrol Kohler SH 265
Fuel tank capacity	3,1 liter	3,1 liter
Fuel cons. At cont. Rated power	1,7 l/h – 3600 rpm	1,7 l/h – 3600 rpm

Working pressure from 232 to 330 bar

Standard equipment

- 1 1 filling connection to choose between
(1a) DIN 232, **(1b)** DIN 300, **(1c)** INT/YOKE 232 bar
- 2 1 filling hose of 1.2 m length

- 3 Frame color Black RAL 9005



Optional

- 1 Autostop
- 2 Digital hour meter
- 3 C-Monitor
- 4 Remote suction hose kit
- 5 Pressure maintaining valve
- 6 Filling connection DRV DIN 232 bar
- 7 Filling connection DRV DIN 300 bar
- 8 Filling connection with gauge DRV DIN 232 bar
- 9 Filling connection with gauge DRV DIN 300 bar

- 10 DIN/INT adapter
 - 11 Filling connection DRV/INT
 - 12 Filling hose. Available: 2 m - 3 m
- Dual output kit 232 bar
- 13 Double outlet T fitting for hoses + 2 filling hoses 1,20 m + 2 filling connection DRV DIN 232 bar
- Dual output kit 300 bar
- 14 Double outlet T fitting for hoses + 2 filling hoses 1,20 m + 2 filling connection DRV DIN 300 bar



Dimensions

Width 78 cm (30.70")

Depth 32 cm (12.59")

Height 35 cm (13.77")

Dry weight

ICON 100 SH

37 kg (81.6 lb)

ICON 100 SK

37 kg (81.6 lb)

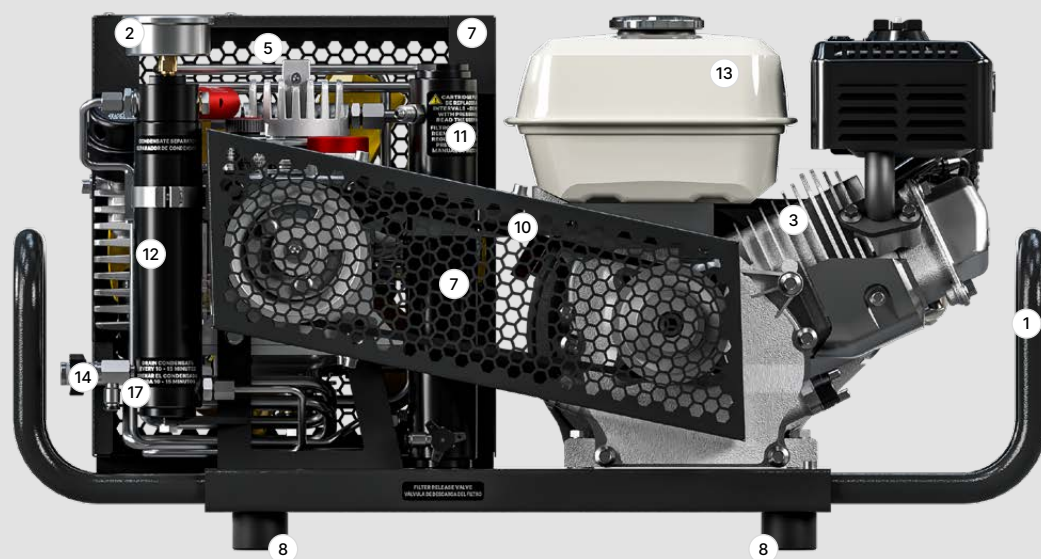

Machine parts

- | | | | | | |
|---|----------------|----|------------------------|----|------------------------------|
| 1 | Frame | 7 | Fan/belt shroud | 13 | Fuel tank |
| 2 | Pressure gauge | 8 | Anti-vibration devices | 14 | Combustion engine air filter |
| 3 | Engine motor | 9 | Cooling fan | 15 | Combustion engine muffler |
| 4 | Pumping unit | 10 | Belt | 16 | Safety valve |
| 5 | Oil filler cap | 11 | Purification system | 17 | Condensate discharge |
| 6 | Air filter | 12 | Condensate separator | | |

Portables line

Icon

Stainless steel

Petrol



Icon Stainless steel 100 SH

Icon Stainless steel 100 SK

Charging rate

100 l/min

100 l/min

Filling time¹

20 min

20 min

Engine power

4,3 kW

Petrol HONDA GP 200

4,1 kW

Petrol Kohler SH 265

¹ Filling time 10 l empty cylinder - 0/200 bar (tolerance ±5%)

Dedicated to the most extreme journeys.

	Icon Stainless steel 100 SH Petrol HONDA GP 200	Icon Stainless steel 100 SK Petrol Kohler SH 265
Fuel tank capacity	3,1 liter	3,1 liter
Fuel cons. At cont. Rated power	1,7 l/h – 3600 rpm	1,7 l/h – 3600 rpm

Working pressure from 232 to 330 bar

Standard equipment

- 1 1 filling connection to choose between (1a) DIN 232, (1b) DIN 300, (1c) INT/YOKE 232 bar
- 2 1 filling hose of 1.2 m length

- 3 Stainless steel frame



Optional

- 1 Autostop
- 2 Digital hour meter
- 3 C-Monitor
- 4 Remote suction hose kit
- 5 Pressure maintaining valve
- 6 Filling connection DRV DIN 232 bar
- 7 Filling connection DRV DIN 300 bar
- 8 Filling connection with gauge DRV DIN 232 bar
- 9 Filling connection with gauge DRV DIN 300 bar

- 10 DIN/INT adapter
 - 11 Filling connection DRV/INT
 - 12 Filling hose. Available: 2 m - 3 m
- Dual output kit 232 bar
- 13 Double outlet T fitting for hoses + 2 filling hoses 1,20 m + 2 filling connection DRV DIN 232 bar
- Dual output kit 300 bar
- 14 Double outlet T fitting for hoses + 2 filling hoses 1,20 m + 2 filling connection DRV DIN 300 bar



Dimensions

Width 78 cm (30.70")

Depth 32 cm (12.59")

Height 35 cm (13.77")

Dry weight

ICON Stainless steel 100 SH

37 kg (81.6 lb)

ICON Stainless steel 100 SK

37 kg (81.6 lb)



Machine parts

- | | | |
|------------------|--------------------------|-------------------------|
| 1 Frame | 7 Fan/belt shroud | 13 Fuel tank |
| 2 Pressure gauge | 8 Anti-vibration devices | 14 Engine air filter |
| 3 Engine motor | 9 Cooling fan | 15 Engine muffler |
| 4 Pumping unit | 10 Belt | 16 Safety valve |
| 5 Oil filler cap | 11 Purification system | 17 Condensate discharge |
| 6 Air filter | 12 Condensate separator | |

Portables line

Mini Compact

Electric



Mini Compact 100 EM

Mini Compact 100 ET

Charging rate

100 l/min

100 l/min

Filling time¹

20 min

20 min

Engine power

2,2 kW
Single-phase electric

3 kW
Three-phase electric

¹ Filling time 10 l empty cylinder - 0/200 bar (tolerance ±5%)

Powerful, portable and a great looking frame.

The **MINI COMPACT** range of compressors are very popular in the marine industry thanks in part to their reinforced, more enveloping chassis. All equipped with the popular MCH 6 pumping unit, they are available with gasoline or electric motors, both three-phase and single-phase. The equipment includes a filling connection for flexible hose with working pressure from 232 to 330 bar. Optional extras include a pressure maintenance valve, automatic condensate drain and auto-stop, all of which allow the product to be tailored to the user's needs.

Working pressure from 232 to 330 bar

Standard equipment

- | | | | |
|---|--|---|--|
| 1 | 1 filling connection to choose between
(1a) DIN 232, (1b) DIN 300, (1c) INT/YOKE 232 bar | 3 | Hour meter
Only for single-phase electric motor |
| 2 | 1 filling hose of 1.2 m length | 4 | Frame color Black RAL 9005 |



Optional

- | | | | |
|---|---|----|--|
| 1 | Autostop | 10 | DIN/INT adapter |
| 2 | Automatic condensate drain with timer
Only for single-phase electric motor | 11 | Filling connection DRV/INT |
| 3 | C-Monitor | 12 | Filling hose. Available: 2 m - 3 m |
| 4 | Remote suction hose kit 3 m | | Dual output kit 232 bar |
| 5 | Pressure maintaining valve | 13 | Double outlet T fitting for hoses + 2 filling hoses 1,20 m +
2 filling connection DRV DIN 232 bar |
| 6 | Filling connection DRV DIN 232 bar | | Dual output kit 300 bar |
| 7 | Filling connection DRV DIN 300 bar | 14 | Double outlet T fitting for hoses + 2 filling hoses 1,20 m +
2 filling connection DRV DIN 300 bar |
| 8 | Filling connection with gauge DRV DIN 232 bar | | |
| 9 | Filling connection with gauge DRV DIN 300 bar | | |



Dimensions

Width 59,2 cm (23.3")

Depth 38 cm (15")

Height 42,7 cm (16.8")

Dry weight

MINI COMPACT 100 EM

47 kg (103.3 lb)

MINI COMPACT 100 ET

47 kg (103.3 lb)

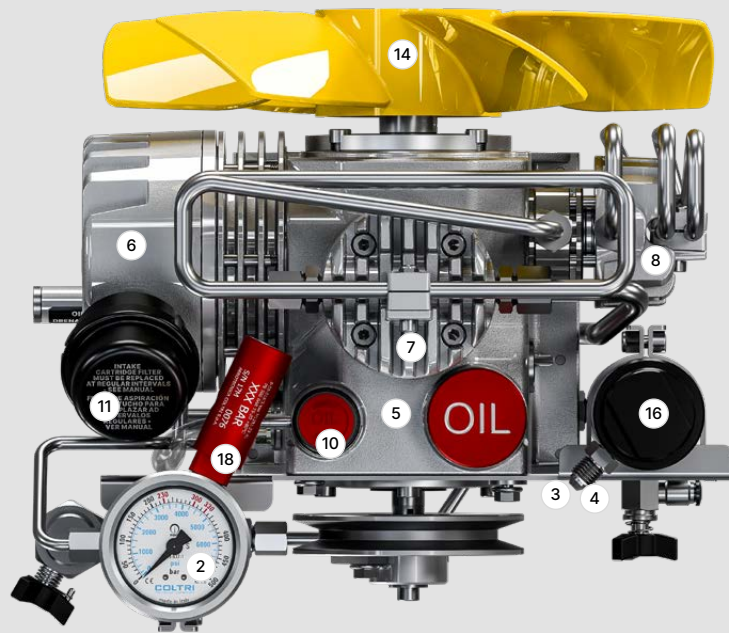

Machine parts

- | | | |
|----------------------------|---------------------------|-------------------------|
| 1 Frame | 8 3rd stage | 15 Belt |
| 2 Pressure gauge | 9 4th stage | 16 Purification system |
| 3 Refill hoses connection | 10 Oil filler cap | 17 Electric motor |
| 4 High pressure air outlet | 11 Air filter | 18 Safety valve |
| 5 Pumping unit | 12 Fan/belt shroud | 19 Condensate drain |
| 6 1st stage | 13 Anti-vibration devices | 20 Condensate discharge |
| 7 2nd stage | 14 Cooling fan | |

Portables line

Mini Compact

Petrol



Compact 100 SH

Charging rate

100 l/min

Filling time¹

3.50 min

Engine power

4,3 kW

Petrol HONDA GP 200

¹ Filling time 10 l empty cylinder - 0/200 bar (tolerance ±5%)

Maximize performance.

Compact 100 SH
Petrol HONDA GP 200

Fuel tank capacity	3,1 liter
Fuel cons. At cont. Rated power	1,7 l/h – 3600 rpm

Working pressure from 232 to 330 bar

Standard equipment

-
- 1 1 filling connection to choose between
(1a) DIN 232, **(1b)** DIN 300, **(1c)** INT/YOKE 232 bar
 - 2 1 filling hose of 1.2 m length
-

-
- 3 Frame color Black RAL 9005
-



Optional

- 1 Autostop
- 2 Digital hour meter
- 3 C-Monitor
- 4 Remote suction hose kit 3 m
- 5 Pressure maintaining valve
- 6 Filling connection DRV DIN 232 bar
- 7 Filling connection DRV DIN 300 bar
- 8 Filling connection with gauge DRV DIN 232 bar
- 9 Filling connection with gauge DRV DIN 300 bar

- 10 DIN/INT adapter
 - 11 Filling connection DRV/INT
 - 12 Filling hose. Available: 2 m - 3 m
- Dual output kit 232 bar
- 13 Double outlet T fitting for hoses + 2 filling hoses 1,20 m + 2 filling connection DRV DIN 232 bar
- Dual output kit 300 bar
- 14 Double outlet T fitting for hoses + 2 filling hoses 1,20 m + 2 filling connection DRV DIN 300 bar



Dimensions

Width 79,8 cm (31.4")

Depth 37 cm (14.5")

Height 43,5 cm (17.1")

Dry weight

MINI COMPACT 100 SH

53 kg (116.8 lb)



Machine parts

- | | | | | | |
|---|----------------|----|------------------------|----|------------------------------|
| 1 | Frame | 7 | Fan/belt shroud | 13 | Fuel tank |
| 2 | Pressure gauge | 8 | Anti-vibration devices | 14 | Combustion engine air filter |
| 3 | Engine motor | 9 | Cooling fan | 15 | Combustion engine muffler |
| 4 | Pumping unit | 10 | Belt | 16 | Safety valve |
| 5 | Oil filler cap | 11 | Purifier filter | 17 | Condensate discharge |
| 6 | Air filter | 12 | Condensate separator | | |

Purification system

Purification system ECO-FILTER

ECO-FILTER disposable cartridge

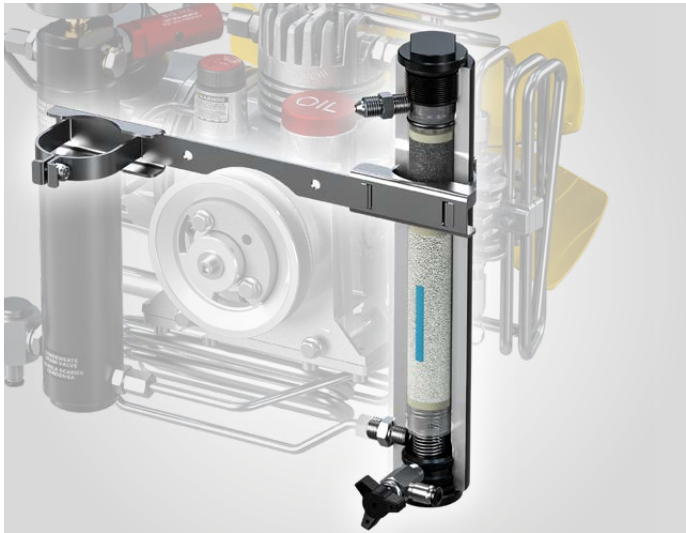

Separator system

- Final separator for removal of oil/water condensate
- Final safety valve, mounted on the separator housing



Purification system ECO-FILTER

Purification system	Eco-Filter
Operating pressure (Standard)	232 bar / 330 bar
Operating pressure max. (PS)	360 bar
Processable air capacity (air inlet temperature in the filter 20° C at 300 bar) ¹	210 m ³

¹ When using a filter cartridge without HOPCALITE CO CATALYST.

When using a cartridge with CO-removal, the processable air capacity is reduced by ca. 20%.

Separator system

Contamination	Maximum content as per DIN EN 12021:2014	Air quality*
H ₂ O	25 mg/m ³	≤ 10 mg/m ³
CO	5 ppm(v)	≤ 4
CO ₂	500 ppm(v)	≤ 500
Oil	0,5 mg/m ³	≤ 0,5 mg/m ³

* Measured at our facility using ASCO HORA 160 ANALYZER.

¹ Only with special filter cartridge with HOPCALITE CO CATALYST. and up to a maximum concentration of 25 ppm CO in intake air. The compressed clean breathing air then contains a maximum of 5 ppm CO.

² The level of CO₂ in the intake air must not exceed the maximum level of CO₂ as per EN 12021:2014

³ Reported values exceed ISO 8573-1 standards.

ECO-FILTER cartridges

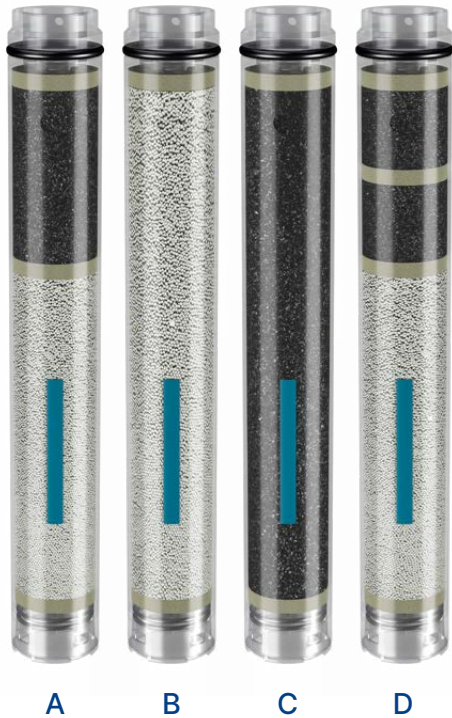

- A with molecular sieve and activated carbon
Standard on electric motor compressors.
- B with molecular sieve
- C with activated carbon
- D with molecular sieve, activated carbon and CO-catalyst
Standard on petrol motor compressors.

Lubricants

Synthetic Coltri Oil ST 755

A fully synthetic oil specifically developed for long lasting lubrication of process gas compressors and especially for breathing air. It provides outstanding performance in all types of compressors.



Special Motor Oil for 1 liter petrol and diesel engines



Optional

Automatic condensate drain with timer

Available only for compressors with electric motor.

The automatic condensate drain removes water from the intermediate separator and the final separator automatically during operation (every 7 minutes).

Composed of:

- 1 x timer
- 1 x solenoid valve



Autostop

Compressor automatically switches off when it reaches the final pressure.









Composed of:

- 1 x Pressure switch
- 230 bar - COD. SC000521/232 (safety valve 250 bar)
- 300 bar - COD. SC000521/300 (safety valve 330 bar)



C-Monitor

Final filter monitoring system, oil change and technical interface.

The interface consists of an LCD display, a button  and two indicators (, ). The decimal points next to the digits are indicator lights to indicate alarms or warnings in progress. Each dot is associated with an explanatory icon (, , ). The icon  indicates an alarm condition while the symbol  indicates normal operation. Press the button  to scroll through the different functions of the menu. When pressed, the function is displayed and after two 2 seconds the corresponding data is displayed.



Tankless line

Eolo 330

Electric - Petrol



Eolo 330 EM

Eolo 330 ET

Eolo 330 SH

Charging rate

330 l/min

330 l/min

330 l/min

Tank capacity

4,5 liters

4,5 liters

4,5 liters

Engine power

2,2 kW

Single-phase electric

3,0 kW

Three-phase electric

3,6 kW

Petrol HONDA GP 200

The **EOLO 330** series is composed of low pressure Coltri breathing air compressors, suitable for professional use and driven by a three-cylinder pumping unit that guarantees excellent performance. Equipped with a filter with interchangeable cartridge, it is ideal for underwater work or with ventilated helmets. The available motorizations are electric, single-phase or three-phase, and Honda internal combustion engines. The watchword is maneuverability, thanks to the built-in tank and the presence of wheels.

Working pressure 8 bar

Dimensions

Width 90 cm (35.4")
Depth 45 cm (17.7")
Height 57 cm (22.4")

Dry weight

EOLO 330 EM 55 kg (121 lb)
EOLO 330 ET 55 kg (121 lb)
EOLO 330 SH 54 kg (119 lb)

Eolo 330 SH
Petrol HONDA GP 200

Fuel tank capacity

3,1 liter

Fuel cons. At cont. Rated power

1,7 l/h – **3600** rpm

Standard equipment

- 1 Breathing air filter
- 2 Adjustable pressure switch

Optional

- 1 Remote suction hose kit 3 m
- 2 2nd stage regulator
- 3 Food grade floating pipe
- 4 Double output T-coupling

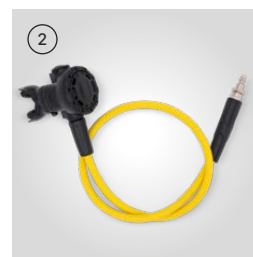

Catalogue

Filling stations

Breathing air

High pressure compressors
for breathing air and technical gases

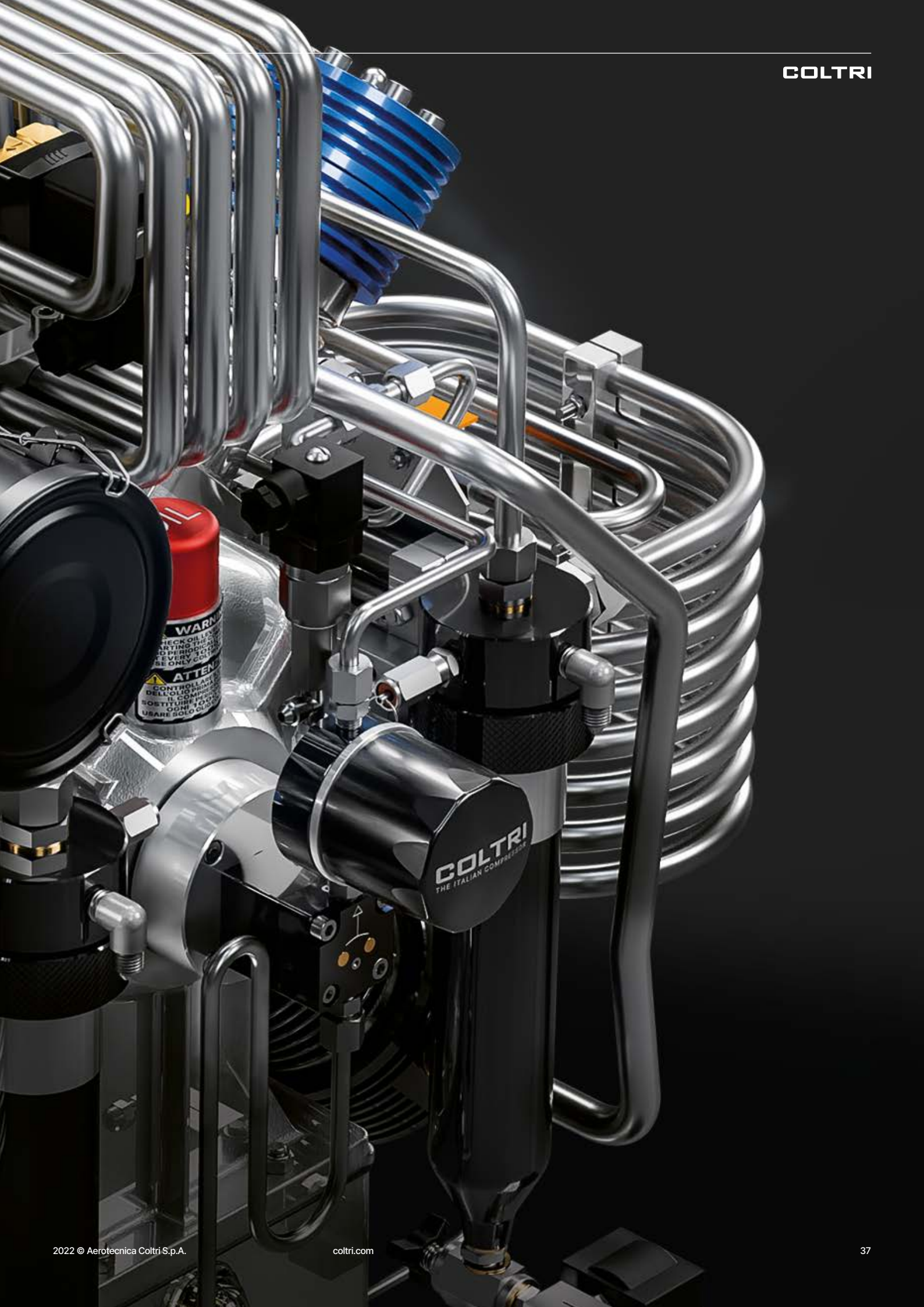

When choosing your Coltri compressor, begin with performance.

Charging rate (l/min.)

Mini Silent Pumping units: 100-125	100 - 125 l/min							
Smart Pumping units: 125-210-235-270-315	125 - 315 l/min							
Mark III Silent Pumping units: 210-235-270-315	210 - 330 l/min							
Ergo Pumping units: 210-235-270-280-315	210 - 315 l/min							
Super Silent Pumping units: 235-315-330	235 - 330 l/min							
Mark III Silent TPS Pumping units: 210-235-270-315-345-380 TPS	210 - 380 l/min							
Ergo TPS Pumping units: 235-270-315-345-380 TPS	235 - 380 l/min							
Super Silent TPS Pumping units: 235-270-315-345-380 TPS	235 - 380 l/min							
Force Four Pumping units: 400-450-550-650					400 - 650 l/min			
Open Pumping units: 450-550-650-750					450 - 750 l/min			
Silent Pumping units: 450-550-650-750					450 - 750 l/min			
Pumping units charging rate (l/min)	0	100	200	300	400	500	600	700

How many cylinders do you want to refill in 1 hour?

Measurement carried out on empty 11-litre cylinder (S 80) - 0/200 bar at 20° C (tolerance $\pm 5\%$)

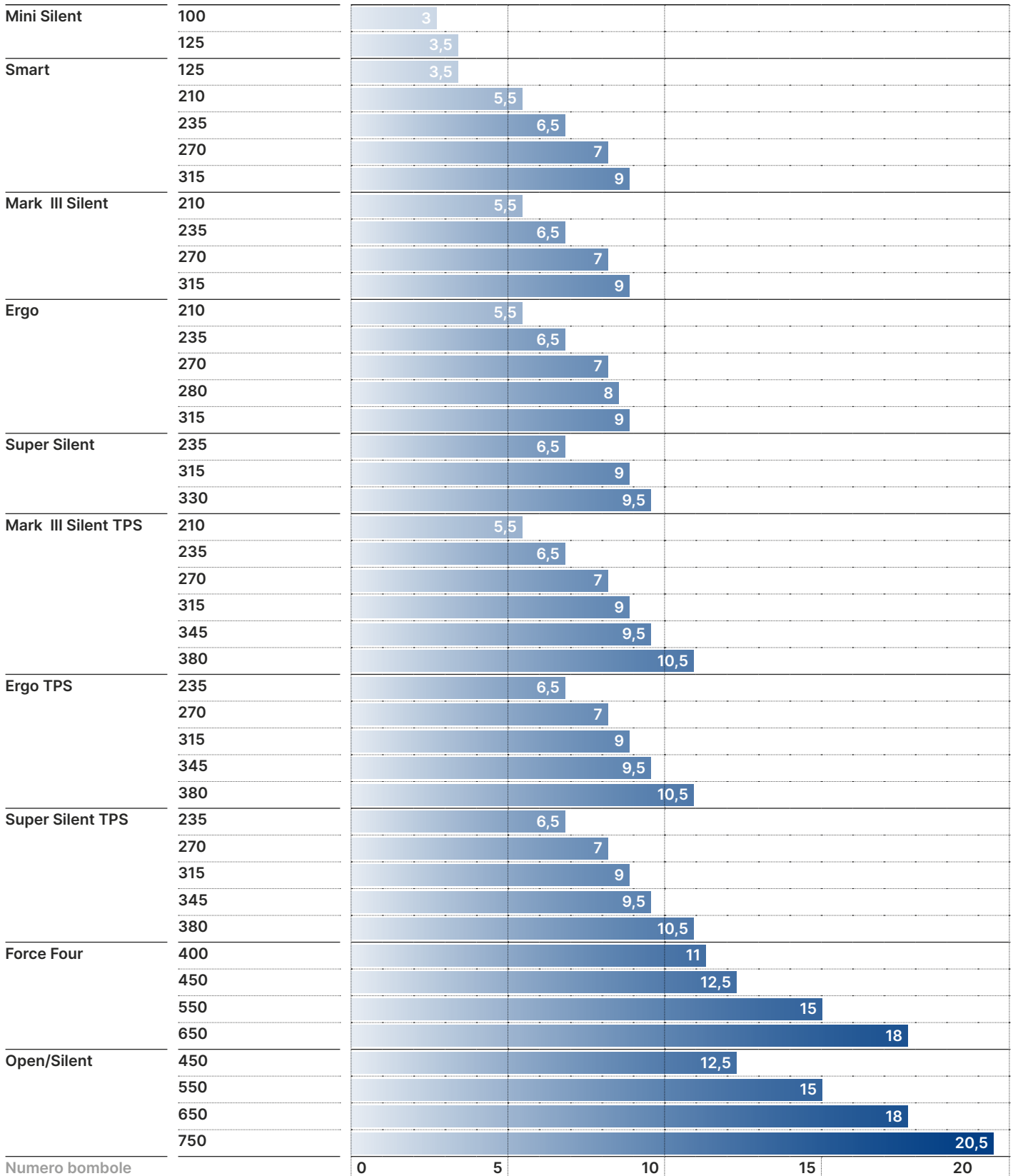

Numero bombole

Compare models and learn more about the right product for you.

LINE / COMPRESSOR	L/MIN	RPM	NOISE LEVEL LPA - DB	DIMENSIONS (W X D X H) CM - IN	CYLINDERS REFILLED IN ONE HOUR*	POWER KW - HP
EFFICIENT LINE						
Mark III Silent 235	235	1270	63	130x730x91 40.5x28.7x35.8	5 cylinders	4 - 5.5
Mark III Silent 315	315	1600	65	90 x 91 x 132 35.4 x 35.8 x 52	6,5 cylinders	5,5 - 7.5
Ergo 235	235	1240	72	63 x 112 x 77 24.8 x 44.1 x 30.3	5 cylinders	4 - 5.5
Ergo 315	315	1600	72	63 x 112 x 77 24.8 x 44.1 x 30.3	6,5 cylinders	5,5 - 7.5
PRIME LINE						
Mark III Silent TPS 235	235	1240	72	93,5 x 130 x 173 35.4 x 36.6 x 52	5 cylinders	4 - 5.5
Mark III Silent TPS 315	315	1600	72	93,5 x 130 x 173 35.4 x 36.6 x 52	6,5 cylinders	5,5 - 7.5
Mark III Silent TPS 345	345	1240	72	93,5 x 130 x 173 35.4 x 36.6 x 52	7 cylinders	7,5 - 10
Mark III Silent TPS 380	380	1400	72	93,5 x 130 x 173 35.4 x 36.6 x 52	8 cylinders	7,5 - 10
Ergo TPS 235	235	1240	72	63 x 112 x 77 24.8 x 44.1 x 30.3	5 cylinders	4 - 5.5
Ergo TPS 315	315	1600	72	63 x 112 x 77 24.8 x 44.1 x 30.3	6,5 cylinders	5,5 - 7.5
Ergo TPS 345	345	1240	72	63 x 112 x 77 24.8 x 44.1 x 30.3	7 cylinders	7,5 - 10
Ergo TPS 380	380	1400	72	63 x 112 x 77 24.8 x 44.1 x 30.3	8 cylinders	7,5 - 10
HEAVY DUTY LINE						
Open 450	450	1050	72	90,5 x 105 x 153 35.6 x 41.4 x 60.2	9 cylinders	7,5 - 10
Open 550	550	1250	72	90,5 x 105 x 153 35.6 x 41.4 x 60.2	11 cylinders	9 - 12,5
Open 650	650	1250	72	90,5 x 105 x 153 35.6 x 41.4 x 60.2	13 cylinders	11 - 15
Open 750	750	1420	72	90,5 x 105 x 153 35.6 x 41.4 x 60.2	15 cylinders	15 - 20

* Value calculated on the refilling of an empty 15-liter cylinder, at 300 bar, at a temperature of +20° C (tolerance +/- 5%).

LINE / COMPRESSOR	L/MIN	RPM	NOISE LEVEL LPA - DB	DIMENSIONS (W X D X H) CM - IN	CYLINDERS REFILLED IN ONE HOUR*	POWER KW - HP
EFFICIENT LINE						
Super Silent 235	235	1270	63	90 x 91 x 132 35.4 x 35.8 x 52	5 cylinders	4 - 5.5
Super Silent 315	315	1600	65	90 x 91 x 132 35.4 x 35.8 x 52	6,5 cylinders	5,5 - 7.5
Super Silent 330	330	1660	65	90 x 91 x 132 35.4 x 35.8 x 52	7 cylinders	7,5 - 10
PRIME LINE						
Super Silent TPS 235	235	1240	63	93,5 x 130 x 173 35.4 x 36.6 x 52	5 cylinders	4 - 5.5
Super Silent TPS 315	315	1600	65	93,5 x 130 x 173 35.4 x 36.6 x 52	6,5 cylinders	5,5 - 7.5
Super Silent TPS 345	345	1240	65	93,5 x 130 x 173 35.4 x 36.6 x 52	7 cylinders	7,5 - 10
Super Silent TPS 380	380	1400	65	93,5 x 130 x 173 35.4 x 36.6 x 52	8 cylinders	7,5 - 10
HEAVY DUTY LINE						
Silent 450	450	1050	67	93,5 x 130 x 173 36.8 x 51.3 x 68.3	9 cylinders	7,5 - 10
Silent 550	550	1250	67	93,5 x 130 x 173 36.8 x 51.3 x 68.3	11 cylinders	9 - 12,5
Silent 650	650	1250	67	93,5 x 130 x 173 36.8 x 51.3 x 68.3	13 cylinders	11 - 15
Silent 750	750	1420	67	93,5 x 130 x 173 36.8 x 51.3 x 68.3	15 cylinders	15 - 20

* Value calculated on the refilling of an empty 15-liter cylinder, at 300 bar, at a temperature of +20° C (tolerance +/- 5%).

Efficient line

Mini Silent

Electric



Mini Silent 100 EM

Mini Silent 100 ET

Mini Silent 125 EM

Mini Silent 125 ET

Charging rate

100 l/min

125 l/min

Refill time¹

23 min

20 min

16 min

16 min

Engine power

2,2 kW

Single-phase electric

3 kW

Three-phase electric

3 kW

Single-phase electric

3 kW

Three-phase electric

¹ Filling time 10 l empty cylinder - 0/200 bar (tolerance ±5%)

Small, quiet and powerful.

Coltri's breathing air compressors of the **Mini SILENT** series, equipped with 100 and 125 l/min pumping units, are characterized by extreme silence, obtained without sacrificing performance. The large space offered by the frame allows the use of a filtering system with Maxifilter. These compressors are available with single-phase or three-phase electric motor and integrated control panel with hour meter, they have automatic condensate drain and autostop as standard. The equipment includes a filling connection for flexible hose with working pressure from 232 to 330 bar.

Working pressure from 232 to 330 bar

Standard equipment

- | | |
|---|---|
| 1 | 1 filling connection to choose between
(1a) DIN 232, (1b) DIN 300 o (1c) INT/YOKE 232 bar |
| 2 | 1 filling hose of 1.2 m length |
| 3 | Hour Meter |
| 4 | Pressure maintaining valve |

- | | |
|---|--|
| 5 | Autostop |
| 6 | Maxifilter filtration system |
| 7 | Auto-drain Condensate System with condensate collection tank |
| 8 | Frame color RAL 7035 + RAL 6018 |

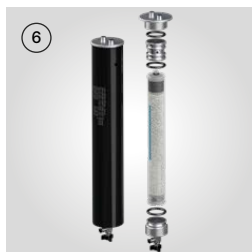
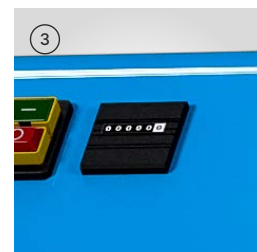
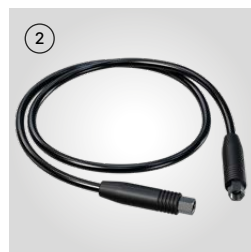

Optional

- | | | | |
|---|---|-------------------------|---|
| 1 | C-Monitor | 8 | Filling hose. Available: 2 m - 3 m |
| 2 | Filling connection DRV DIN 232 bar | Dual output kit 232 bar | |
| 3 | Filling connection DRV DIN 300 bar | 9 | Double outlet T fitting for hoses + 2 filling hoses 1,20 m + 2 filling connection DRV DIN 232 bar |
| 4 | Filling connection with gauge DRV DIN 232 bar | Dual output kit 300 bar | |
| 5 | Filling connection with gauge DRV DIN 300 bar | 10 | Double outlet T fitting for hoses + 2 filling hoses 1,20 m + 2 filling connection DRV DIN 300 bar |
| 6 | DIN/INT adapter | | |
| 7 | Filling connection DRV DIN/INT | | |

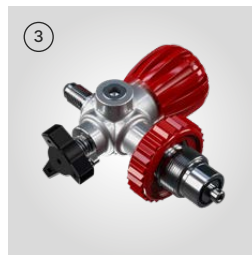

Mini Silent 100 EM



Mini Silent 125 ET

Dimensions

Width 71,5 cm (28,1")
 Depth 67 cm (26.4")
 Height 110 cm (43.3")

Dry weight

MINI SILENT 100 EM
 84,5 kg (186 lb)

MINI SILENT 100 ET
 105 kg (231 lb)

MINI SILENT 125 EM
 84,5 kg (186 lb)

MINI SILENT 125 ET
 105 kg (231 lb)

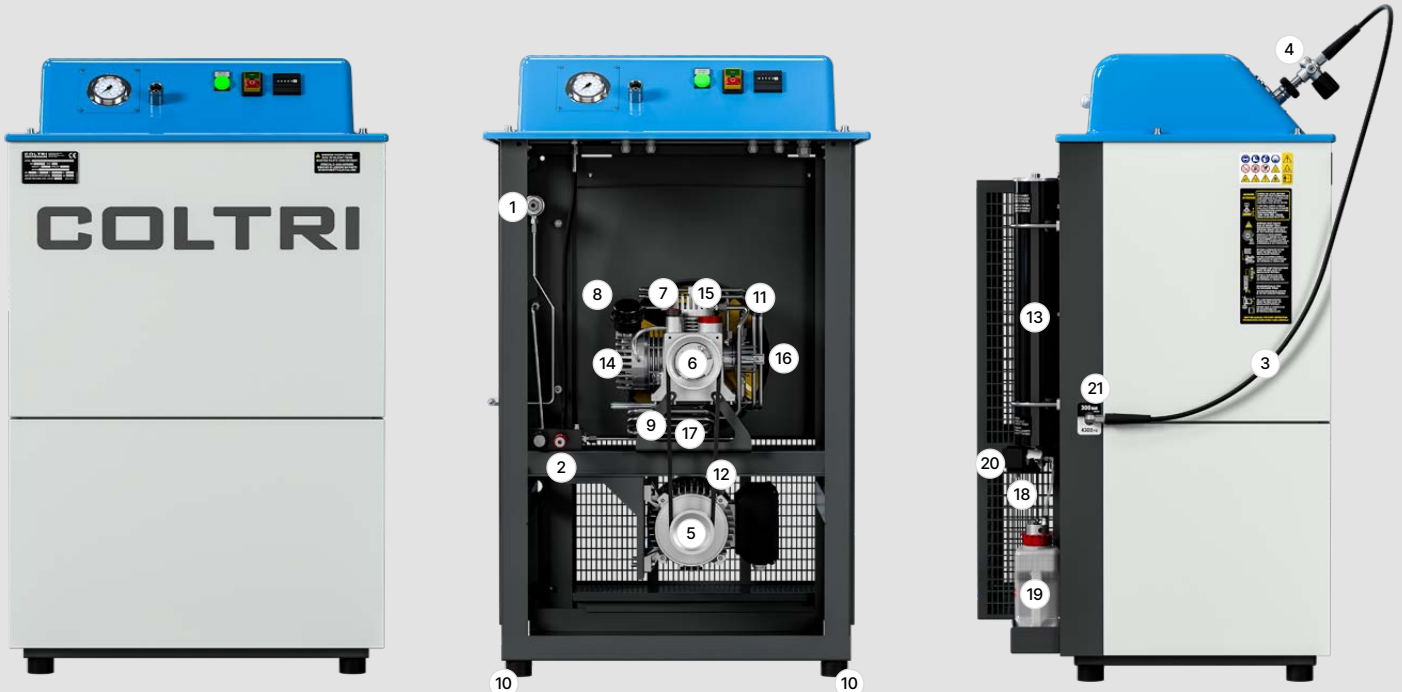
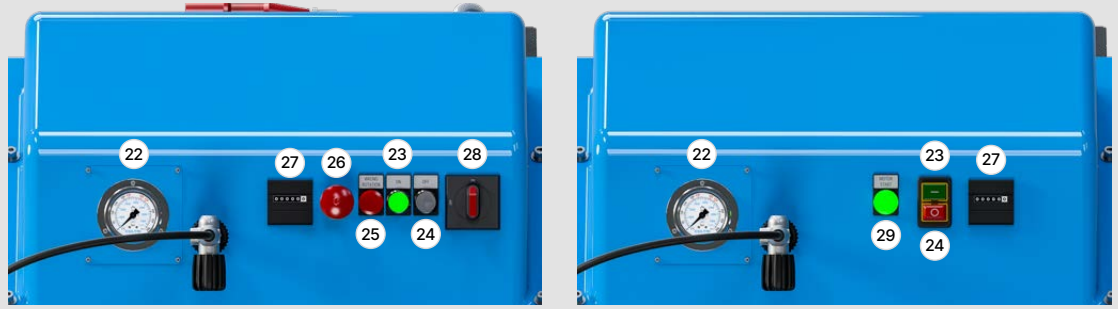

Machine parts

- | | | |
|---------------------------|-----------------------------------|------------------------------------|
| 1 Frame | 11 Cooling fan | 21 Refill hoses connection |
| 2 Safety valve | 12 Belt | 22 Working pressure gauge |
| 3 Hose | 13 Purifier filter | 23 ON pushbutton |
| 4 Refill valve | 14 1st Stage | 24 STOP pushbutton |
| 5 Engine | 15 2nd Stage | 25 Condensate discharge pushbutton |
| 6 Compressor | 16 3rd Stage | 26 Emergency pushbutton |
| 7 Oil filler cap | 17 4th Stage | 27 Hour counter |
| 8 Air filter | 18 Condensate discharge valve | 28 Selector switch ON/OFF |
| 9 Oil discharge plug | 19 Condensate collection can | 29 Power indicator light |
| 10 Anti-vibration devices | 20 Automatic condensate discharge | |

Efficient line

Smart

Electric



Smart 125 EM¹

Smart 210 EM¹

Smart 235 ET

Smart 270 EM¹

Smart 315 ET

Charging rate

125 l/min

210 l/min

235 l/min

270 l/min

315 l/min

Refill time²

16 min

10 min

8.30 min

7.20 min

6.20 min

Engine power

3 kW

Single-phase electric

4 kW

Single-phase electric

4 kW

Three-phase elec.

5,5 kW

Single-phase electric

5,5 kW

Three-phase elec.

¹ Data referred to the maximum pressure of 232 bar

² Filling time for 10 l empty cylinder - 0/200 bar (tolerance ±5%)

The evolution of the species.

SMART breathing air compressors represent the evolution of the **STANDARD**, one of the best known and biggest selling models in the world. They are equipped with two connections for high pressure hoses, a single or three phase electric motor, indestructible pumping units and a compact frame with handles for easier transport. Available options: external refilling panels, electrical display with automatic condensate drainage, and autostop pressure gauge.

Working pressure from 232 to 420 bar

Standard equipment

- | | |
|---|---|
| 1 | 2 filling connections to choose between
(1a) DIN 232, (1b) DIN 300 o (1c) INT/YOKE 232 bar |
| 2 | 2 filling hoses of 1.2 m length |
| 3 | Pressure maintaining valve |

- | | |
|---|------------------------------|
| 4 | Maxifilter filtration system |
| 5 | Oil sight glass |
| 6 | Carrying handles |
| 7 | Frame color Blue RAL 5015 |

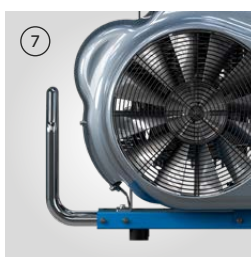

Optional

- | | | | |
|---|--|----|--|
| 1 | C-Monitor | 6 | DRV DIN 300 bar with gauge |
| 2 | Remote control panel | 7 | DIN/INT adapter |
| 3 | Remote filling panel single pressure
(chosen from DRV DIN 232 bar, DRV DIN 300 bar or DRV INT/YOKE 232 bar) | 8 | Filling connection DRV DIN/INT |
| 4 | Remote filling panel double pressure
(chosen from DRV DIN 232 bar + DRV DIN 300 bar or DRV INT/YOKE 232 bar + DRV DIN 300 bar). Including Priority Panel. | 9 | Filling hose. Available: 1,5 m - 2,0 m
- 3,0 m - 4,0 m - 5,0 m - 8,0 m - 10,0 m |
| 5 | DRV DIN 232 bar with gauge | 10 | Stainless steel frame with MOQ |

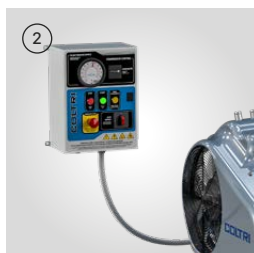

Dimensions

Width 100 cm (39.9")

Depth 46 cm (18.1")

Height 70 cm (27.5")

Dry weight

SMART 125 EM

93 kg (205 lb)

SMART 210 EM

100 kg (220 lb)

SMART 235 ET

95 kg (210 lb)

SMART 270 ET

105 kg (231 lb)

SMART 315 ET

105 kg (231 lb)

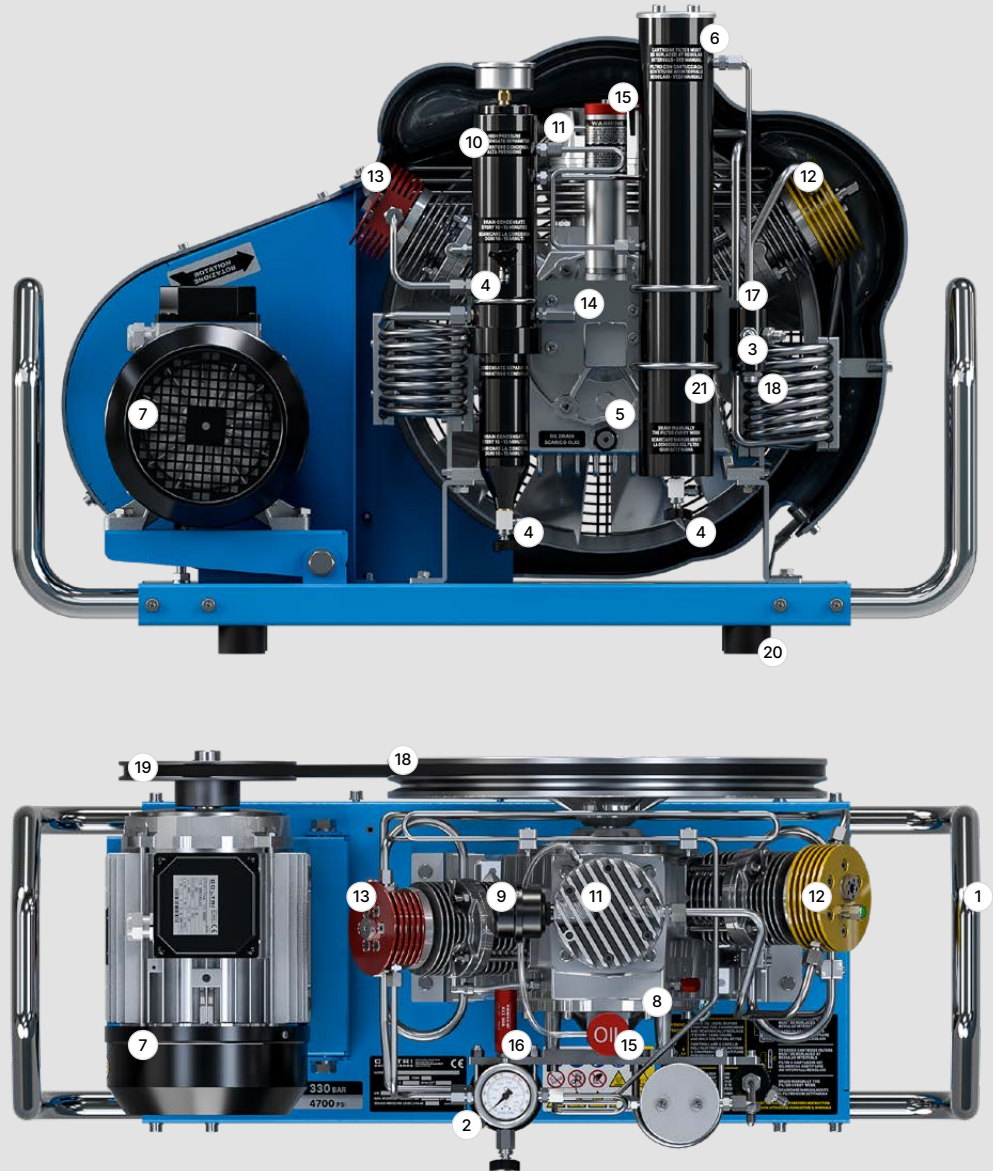

Machine parts

- | | | | | | |
|---|-----------------------------|----|----------------------|----|-----------------------|
| 1 | Frame | 8 | Pumping unit | 15 | Oil filler plug |
| 2 | Pressure gauge | 9 | Air filter | 16 | Safety valve |
| 3 | Refill hoses connection | 10 | Condensate separator | 17 | Maintenance valve |
| 4 | Condensate discharge valves | 11 | 1st stage | 18 | Cooling fan |
| 5 | Oil discharge valves | 12 | 2nd stage | 19 | Belt |
| 6 | Purification system | 13 | 3rd stage | 20 | Anti-vibration device |
| 7 | Electric motor | 14 | Monobloc | 21 | Oil level |

Efficient line

Mark III Silent

Electric



Mark III Silent
210 EM¹

Mark III Silent
235 ET

Mark III Silent
270 EM¹

Mark III Silent
315 ET

Charging rate

210 l/min

235 l/min

270 l/min

315 l/min

Refill time²

10 min

8.30 min

7.20 min

6.20 min

Engine power

4 kW

Single-phase electric

4 kW

Three-phase electric

5,5 kW

Single-phase electric

5,5 kW

Three-phase electric

¹ Data referred to the maximum pressure of 232 bar

² Filling time 10 l empty cylinder - 0/200 bar (tolerance ±5%)

Control is everything.

The **Mark III Silent** model is designed with control systems to effectively monitor all operations: interstage pressure, oil level, internal cabin temperature and rotation direction detector. With two connections for high pressure flexible hoses, it is equipped with electric motors and powerful pumping units, automatic condensate drain and electrical panel for managing the automatic compressor shutdown. Available options include the remote charging panel.

Working pressure from 232 to 420 bar

Standard equipment

1	2 filling connections to choose between (1a) DIN 232, (1b) DIN 300 o (1c) INT/YOKE 232 bar	7	Phase controller that prohibits reverse rotation
2	2 filling hoses of 1.2 m length	8	Pressure switch with automatic switch-off
3	Pressure maintaining valve	9	Oil sight glass
4	Interstage control gauges	10	Auto-drain Condensate System with condensate collection tank
5	Maxifilter filtration system	11	Frame color Blue RAL 5015
6	Cabin temperature with automatic switch-off		



Optional

- 1 C-Monitor

- 2 Remote filling panel single pressure
(chosen from DRV DIN 232 bar, DRV DIN 300 bar or DRV INT/YOKE 232 bar)

- 3 Remote filling panel double pressure
(chosen from DRV DIN 232 bar + DRV DIN 300 bar or DRV INT/YOKE 232 bar + DRV DIN 300 bar). Including Priority Panel.

- 4 Filling connection with gauge DRV DIN 232 bar

- 5 Filling connection with gauge DRV DIN 300 bar

- 6 DIN/INT adapter

- 7 Filling connection IQR/INT

- 8 Presec, filter control system

- 9 SAM sensors CO + CO₂ + H₂O
Available in version with VOC.

- 10 Tornado refrigerator - Dryer
Available in 350 bar or 420 bar versions.

- 11 Filling hose. Available: 1,5 m - 2,0 m
3,0 m - 4,0 m - 5,0 m - 8,0 m - 10,0 m

- 12 Stainless steel frame with MOQ

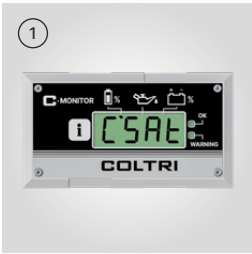

Dimensions

Width 103 cm (40.5")
 Depth 73 cm (28.7")
 Height 91 cm (35.8")

Dry weight

MARK III SILENT 210 EM
 162 kg (357 lb)
MARK III SILENT 235 ET
 162 kg (357 lb)
MARK III SILENT 270 EM
 168 kg (370 lb)
MARK III SILENT 315 ET
 168 kg (370 lb)

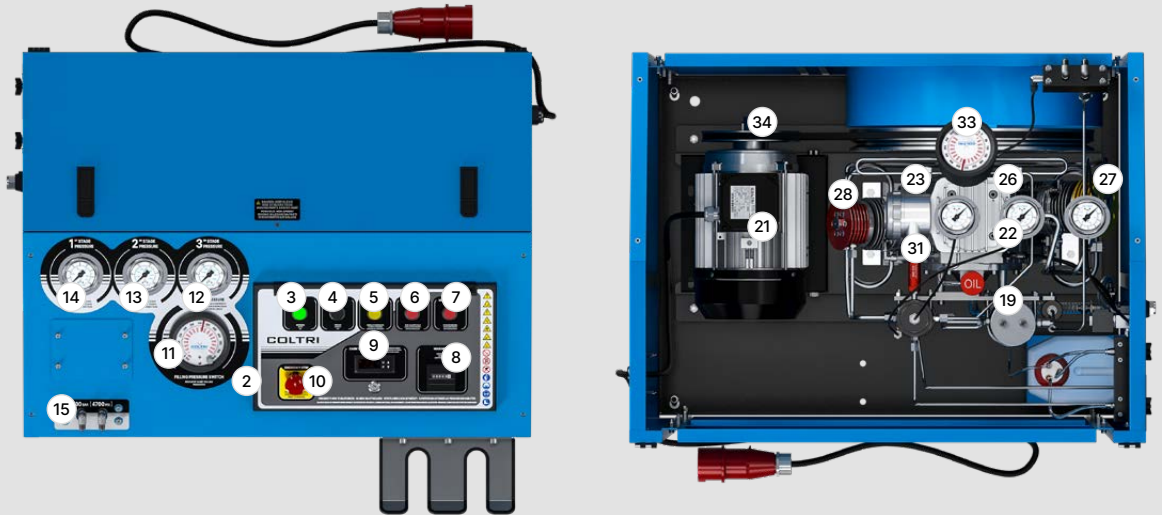

Machine parts

- | | | |
|--|--------------------------------|----------------------------|
| 1 Frame | 12 3rd stage pressure gauge | 24 LP condensate separator |
| 2 Control panel | 13 2nd stage pressure gauge | 25 HP condensate separator |
| 3 ON pushbutton | 14 1st stage pressure gauge | 26 1st stage |
| 4 Stop pushbutton | 15 Refill hoses connection | 27 2nd stage |
| 5 Condensate discharge pushbutton | 16 Condensate discharge valves | 28 3rd stage |
| 6 Oil level warning light | 17 Oil level | 29 Monobloc |
| 7 Direction of rotation indicator light | 18 Oil discharge valves | 30 Oil filler plug |
| 8 Hour counter | 19 Purification system | 31 Safety valve |
| 9 Cabinet interior / cooling air temperature | 20 Condensate collection can | 32 Maintenance valve |
| 10 Emergency pushbutton | 21 Electric motor | 33 Cooling fan |
| 11 Automatic shutdown pressure switch | 22 Pumping unit | 34 Belt |
| | 23 Air filter | |

Efficient line

Ergo

Electric



Ergo 210 EM¹

Ergo 235 ET

Ergo 270 EM¹

Ergo 315 ET

Charging rate

210 l/min

235 l/min

270 l/min

315 l/min

Refill time²

10 min

8.30 min

7.20 min

6.20 min

Engine power

4 kW

Single-phase electric

4 kW

Three-phase electric

5,5 kW

Single-phase electric

5,5 kW

Three-phase electric

¹ Data referred to the maximum pressure of 232 bar

² Filling time 10 l empty cylinder - 0/200 bar (tolerance ±5%)

Maximum efficiency in motion.

Practical and lightweight, **ERGO** combines robustness and great operational efficiency. Equipped with two different pumping units, it can be powered by electric motors or Honda petrol/Kohler diesel engines. It is equipped with a monitoring panel complete with interstage pressure gauges, autostop with adjustable pressure switch, automatic condensate drain and rotation direction control. There are two connections for high pressure hoses (from 232 to 330 bar) and a Maxifilter filter system. The remote charging panel is available as an option.

Working pressure from 232 to 420 bar

Standard equipment

1	2 filling connections to choose between (1a) DIN 232, (1b) DIN 300 o (1c) INT/YOKE 232 bar	7	Phase controller that prohibits reverse rotation
2	2 filling hoses of 1.2 m length	8	Pressure switch with automatic switch-off
3	Pressure maintaining valve	9	Oil sight glass
4	Interstage control gauges	10	Auto-drain Condensate System with condensate collection tank
5	Maxifilter filtration system	11	Frame color Blu RAL 5002
6	Cabin temperature with automatic switch-off		

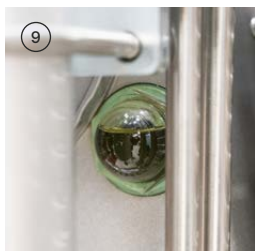
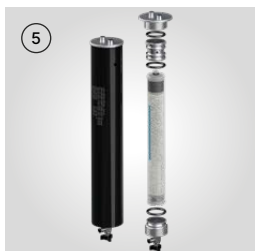

Optional

- 1 C-Monitor

- 2 Remote filling panel single pressure
(chosen from DRV DIN 232 bar, DRV DIN 300 bar or DRV INT/YOKE 232 bar)

- 3 Remote filling panel double pressure
(chosen from DRV DIN 232 bar + DRV DIN 300 bar or DRV INT/YOKE 232 bar + DRV DIN 300 bar). Including Priority Panel.

- 4 Filling connection with gauge DRV DIN 232 bar

- 5 Filling connection with gauge DRV DIN 300 bar

- 6 DIN/INT adapter

- 7 Filling connection DRV DIN/INT

- 8 Filling hose. Available: 1,5 m - 2,0 m
3,0 m - 4,0 m - 5,0 m - 8,0 m - 10,0 m

- 9 Wheel kit

- 10 Stainless steel frame with MOQ



Dimensions

Width 112 cm (44.1")
 Depth 63 cm (24.8")
 Height 77 cm (30.3")

Dry weight

ERGO 210 EM
 159 kg (350 lb)
ERGO 235 ET
 159 kg (350 lb)
ERGO 270 EM
 147 kg (324 lb)
ERGO 315 ET
 152 kg (335 lb)

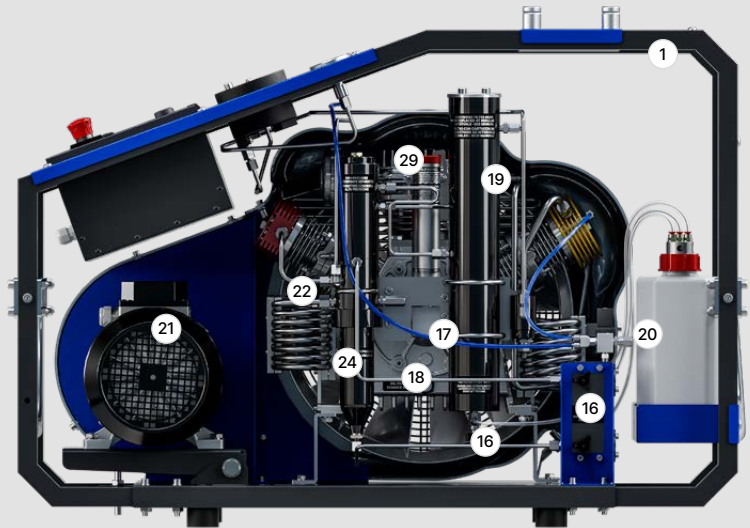

Machine parts

- | | | |
|--|--------------------------------|-------------------------------|
| 1 Frame | 12 3rd stage pressure gauge | 24 Final condensate separator |
| 2 Control panel | 13 2nd stage pressure gauge | 25 1st stage |
| 3 ON pushbutton | 14 1st stage pressure gauge | 26 2nd stage |
| 4 Stop pushbutton | 15 Refill hoses connection | 27 3rd stage |
| 5 Condensate discharge pushbutton | 16 Condensate discharge valves | 28 Monoblock |
| 6 Oil level warning light | 17 Oil level | 29 Oil filler plug |
| 7 Direction of rotation indicator light | 18 Oil discharge valves | 30 Safety valve |
| 8 Hour counter | 19 Purification system | 31 Maintenance valve |
| 9 Cabinet interior/cooling air temperature | 20 Condensate collection tank | 32 Cooling fan |
| 10 Emergency pushbutton | 21 Electric motor | 33 Belt |
| 11 Automatic shutdown pressure switch | 22 Pumping unit | |
| | 23 Air filter | |

Efficient line

Ergo

Petrol



Ergo 270 SH

Ergo 270 SH FA

Charging rate

270 l/min

270 l/min

Refill time¹

7.20 min

7.20 min

Engine power

6,6 kW

Petrol HONDA GX 270

6,6 kW

Petrol HONDA GX 270 Electric starter

¹ Filling time 10 l empty cylinder - 0/200 bar (tolerance ±5%)

Ergo 270 SH
Petrol HONDA GX 270

Ergo 270 SH FA
Petrol HONDA GX 270 Eit. Str.

Fuel tank capacity

5,3 liter

Fuel cons. At cont. Rated power

2,4 l/h – **3600** rpm

Working pressure from 232 to 420 bar

Standard equipment

- 1 2 filling connections to choose between (1a) DIN 232, (1b) DIN 300 o (1c) INT/YOKE 232 bar
- 2 2 filling hoses of 1.2 m length
- 3 Pressure maintaining valve
- 4 Maxifilter purification system
- 5 Oil sight glass

- 6 Auto-drain Condensate System with condensate collection tank. Only for FA model
- 7 Electric starter. Only for FA model
- 8 Pressure switch auto shut-off. Only for FA model
- 9 Frame color Blu RAL 5002

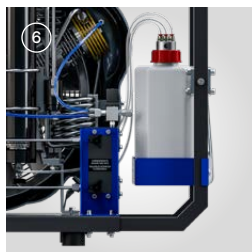
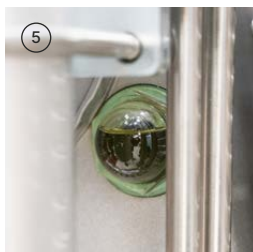

Optional

- | | |
|----|--|
| 1 | C-Monitor |
| 2 | Remote filling panel single pressure
(chosen from DRV DIN 232 bar, DRV DIN 300 bar or DRV INT/YOKE 232 bar) |
| 3 | Remote filling panel double pressure
(chosen from DRV DIN 232 bar + DRV DIN 300 bar or DRV INT/YOKE 232 bar + DRV DIN 300 bar). Including Priority Panel. |
| 4 | DRV DIN 232 bar with gauge |
| 5 | DRV DIN 300 bar with gauge |
| 6 | DIN/INT adapter |
| 7 | Filling connection DRV DIN/INT |
| 8 | Filling hose. Available: 1,5 m - 2,0 m
- 3,0 m - 4,0 m - 5,0 m - 8,0 m - 10,0 m |
| 9 | Auto-drain Condensate System with condensate collection tank |
| 10 | Electric starter |
| 11 | Digital hour meter |
| 12 | Wheel kit |
| 13 | Stainless steel frame with MOQ |

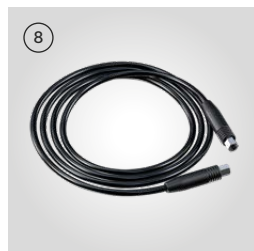
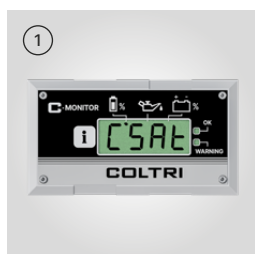

Dimensions

Width 112 cm (44.1")
 Depth 63 cm (24.8")
 Height 77 cm (30.3")

Dry weight

ERGO 270 SH
 121 kg (267 lb)
ERGO 270 SH FA
 121 kg (267 lb)

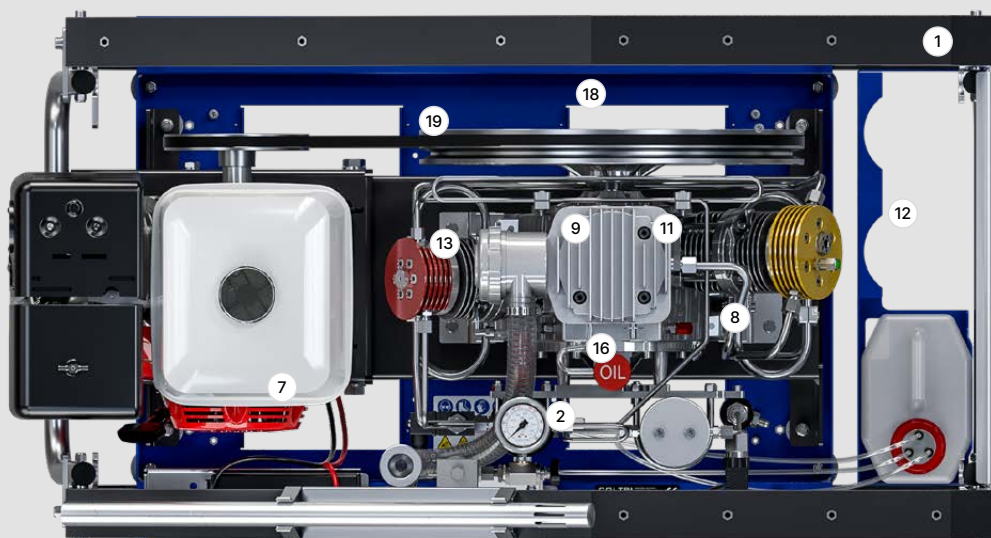
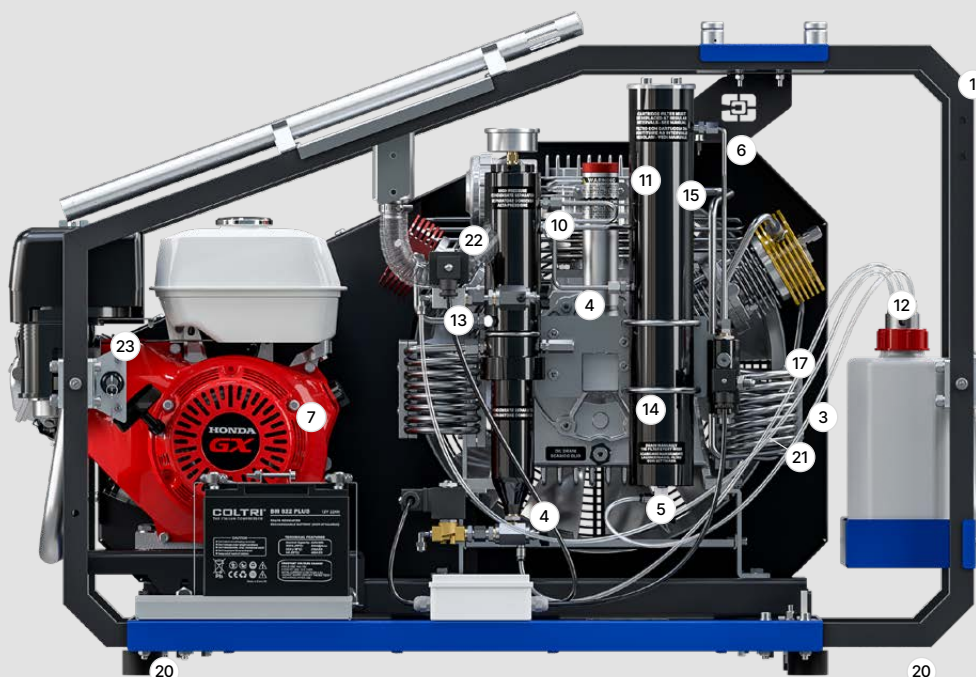

Machine parts

- | | | | | | |
|---|----------------------------|----|----------------------|----|--|
| 1 | Frame | 9 | Intake air filter | 17 | Pressure maintenance valve |
| 2 | Pressure gauge | 10 | Condensate separator | 18 | Cooling fan |
| 3 | Refill hoses connection | 11 | 1st stage | 19 | Belt |
| 4 | Automatic condensate drain | 12 | 2nd stage | 20 | Anti-vibration device |
| 5 | Oil discharge valves | 13 | 3rd stage | 21 | Oil level |
| 6 | Purifier filter | 14 | Monoblock crankcase | 22 | Automatic shutoff with pressure switch |
| 7 | Internal combustion engine | 15 | Oil filler plug | 23 | Electric starter with battery |
| 8 | Compressor | 16 | Safety valve | | |

Efficient line

Ergo

Diesel

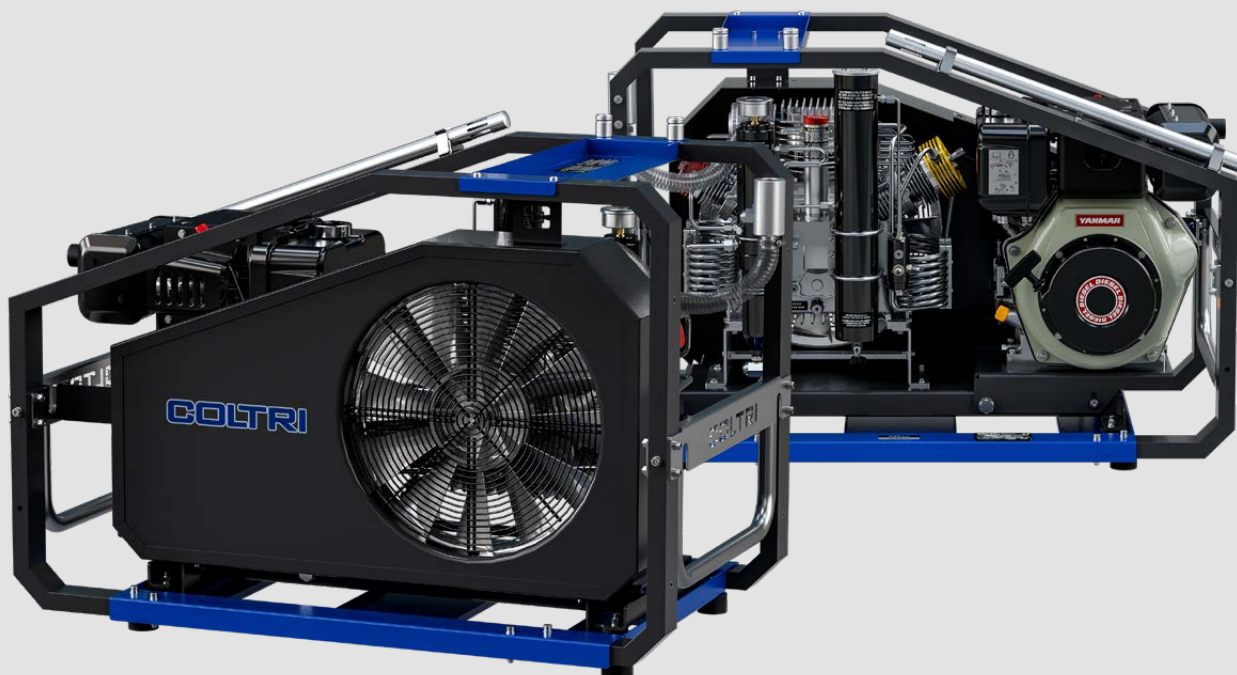

Ergo 280 DY

Ergo 280 DY FA

Charging rate

280 l/min

280 l/min

Refill time¹

7.20 min

7.20 min

Engine power

6,8 kW
Diesel Yanmar

6,8 kW
Diesel Yanmar Electric starter

Ergo 280 DY
Diesel Yanmar

Ergo 280 DY FA
Diesel Yanmar Electric starter

Fuel tank capacity

5,3 liter

Fuel cons. At cont. Rated power

2,4 l/h – **3600** rpm

Working pressure from 232 to 420 bar

Standard equipment

- 1 2 filling connections to choose between (1a) DIN 232, (1b) DIN 300 o (1c) INT/YOKE 232 bar
- 2 2 filling hoses of 1.2 m length
- 3 Maxifilter purification system
- 4 Auto-drain Condensate System with condensate collection tank. Only for FA model

- 5 Electric starter. Only for FA model
- 6 Automatic switch-off. Solo per modello FA
- 7 Frame color Blu RAL 5002 - RAL 9005



Optional

- 1 C-Monitor

- 2 Remote filling panel single pressure
(chosen from DRV DIN 232 bar, DRV DIN 300 bar or DRV INT/YOKE 232 bar)

- 3 Remote filling panel double pressure
(chosen from DRV DIN 232 bar + DRV DIN 300 bar or DRV INT/YOKE 232 bar + DRV DIN 300 bar). Including Priority Panel.

- 4 DRV DIN 232 bar with gauge

- 5 DRV DIN 300 bar with gauge

- 6 DIN/INT adapter

- 7 Filling connection DRV DIN/INT

- 8 Filling hose. Available: 1,5 m - 2,0 m
- 3,0 m - 4,0 m - 5,0 m - 8,0 m - 10,0 m

- 9 Digital hour meter

- 10 Wheel kit

- 11 Stainless steel frame with MOQ



Dimensions

Width 118 cm (46.5")

Depth 63 cm (24.8")

Height 77 cm (30.3")

Dry weight

ERGO 280 DY

164 kg / 361 lb

ERGO 280 DY FA

164 kg / 361 lb

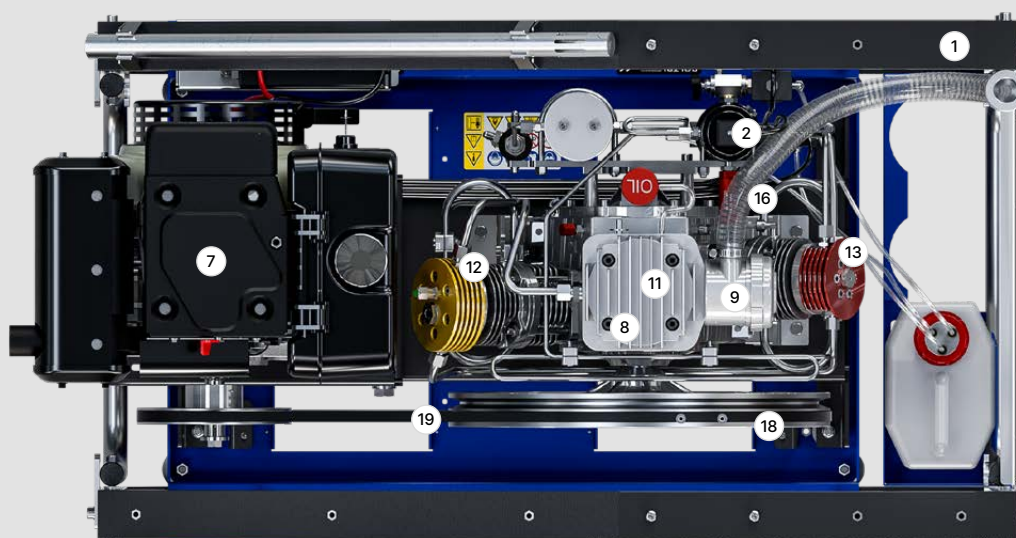
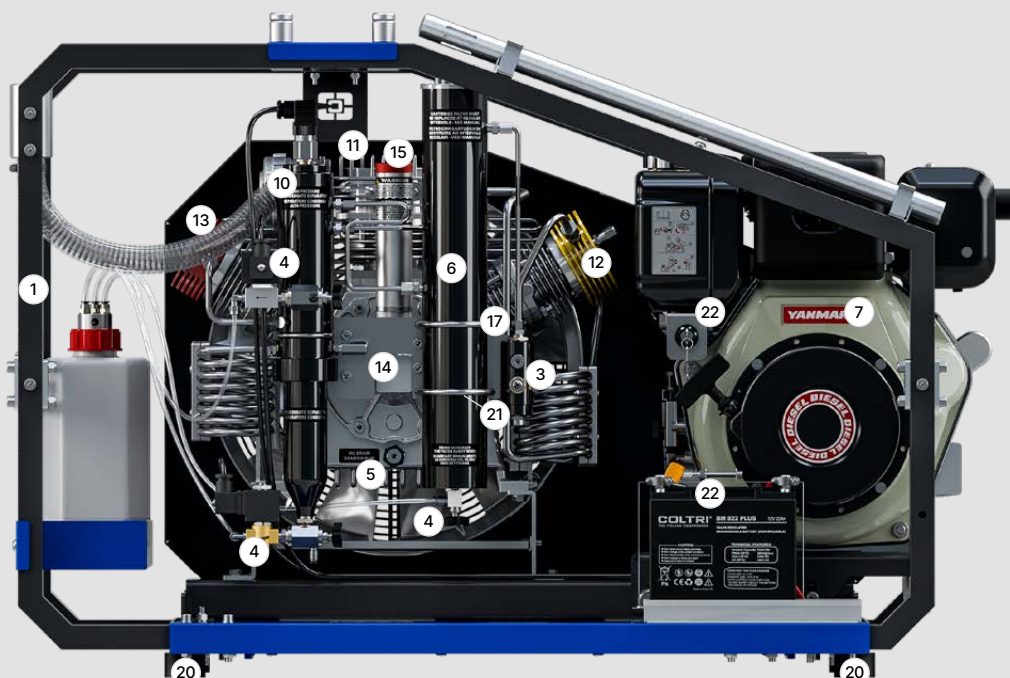

Machine parts

- | | | |
|--|-------------------------|----------------------------------|
| 1 Frame | 8 Pumping unit | 16 Safety valve |
| 2 Automatic shutoff with pressure switch | 9 Intake air filter | 17 Pressure maintenance valve |
| 3 Refill hoses connection | 10 Condensate separator | 18 Cooling fan |
| 4 Automatic condensate drain | 11 1st stage | 19 Belt |
| 5 Oil discharge valves | 12 2nd stage | 20 Anti-vibration device |
| 6 Purifier filter | 13 3rd stage | 21 Oil level |
| 7 Internal combustion engine | 14 Monoblock crankcase | 22 Electric starter with battery |
| | 15 Oil filler plug | |

Efficient line

Super Silent

Electric



Super Silent 235 ET

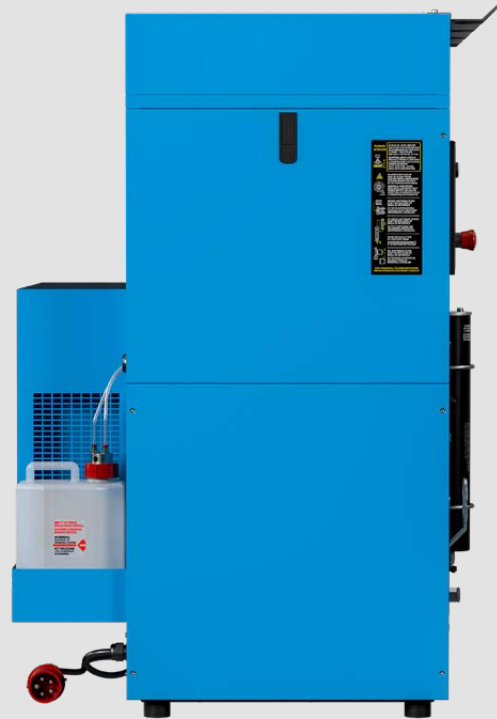

Super Silent 315 ET

Super Silent 330 ET

Charging rate

235 l/min

315 l/min

330 l/min

Refill time¹

8.30 min

6.20 min

6.00 min

Engine power

4 kW

Three-phase electric

5,5 kW

Three-phase electric

7,5 kW

Three-phase electric

¹ Filling time 10 l empty cylinder - 0/200 bar (tolerance ±5%)

Super, without the noise.

The **SUPER SILENT** model stands out for its outstanding noise reduction. Easy to use, it features a high monitoring capability through control systems that track compressor operations. Standard equipment includes: two connections for high pressure hoses, interstage pressure gauge, oil level and internal cabin temperature control, rotation detector, electric motor, automatic condensate drain and autostop. Choose the best pumping group for your needs.

Working pressure from 232 to 420 bar

Standard equipment

- | | | | |
|---|--|----|--|
| 1 | 2 filling connections to choose between
(1a) DIN 232, (1b) DIN 300 o (1c) INT/YOKE 232 bar | 7 | Phase controller that prohibits reverse rotation |
| 2 | 2 filling hoses of 1.2 m length | 8 | Pressure switch with automatic switch-off |
| 3 | Pressure maintaining valve | 9 | Oil sight glass |
| 4 | Interstage control gauges | 10 | Auto-drain Condensate System with condensate collection tank |
| 5 | Maxifilter filtration system | 11 | Frame color Blue RAL 5015 |
| 6 | Cabin temperature with automatic switch-off | | |

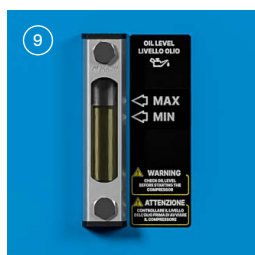
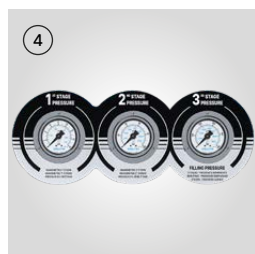
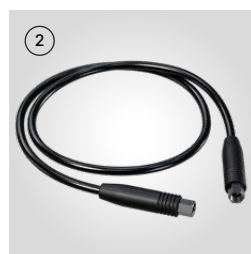

Optional

- 1 C-Monitor

- 2 Remote filling panel single pressure
(chosen from DRV DIN 232 bar, DRV DIN 300 bar or DRV INT/YOKE 232 bar)

- Remote filling panel double pressure
- 3 (chosen from DRV DIN 232 bar + DRV DIN 300 bar or DRV INT/YOKE 232 bar + DRV DIN 300 bar). Including Priority Panel.

- 4 Filling connection with gauge DRV DIN 232 bar

- 5 Filling connection with gauge DRV DIN 300 bar

- 6 DIN/INT adapter

- 7 Filling connection DRV DIN/INT

- 8 SAM sensors CO + CO2 + H2O
Available in version with VOC.

- 9 Filling hose. Available: 1,5 m - 2,0 m
3,0 m - 4,0 m - 5,0 m - 8,0 m - 10,0 m

- 10 Stainless steel frame with MOQ



Dimensions

Width 90 cm (35.4")

Depth 91 cm (35.8")

Height 132 cm (53")

Dry weight

SUPER SILENT 235 ET

192 kg (423 lb)

SUPER SILENT 315 ET

202 kg (445 lb)

SUPER SILENT 330 ET

202 kg (445 lb)

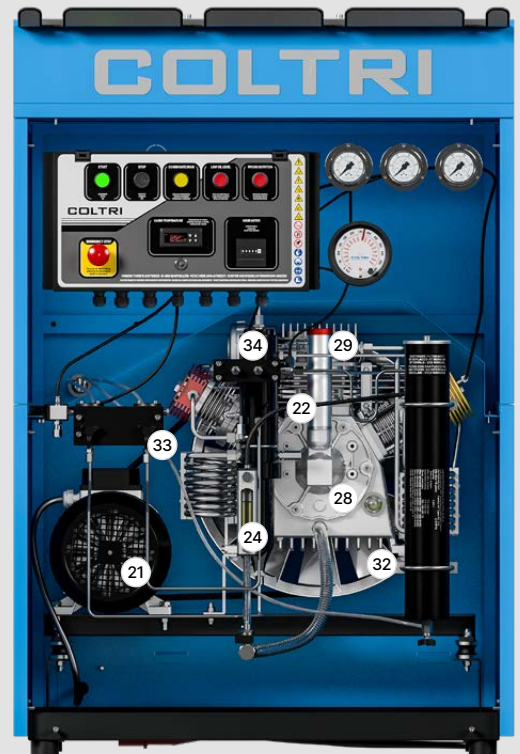
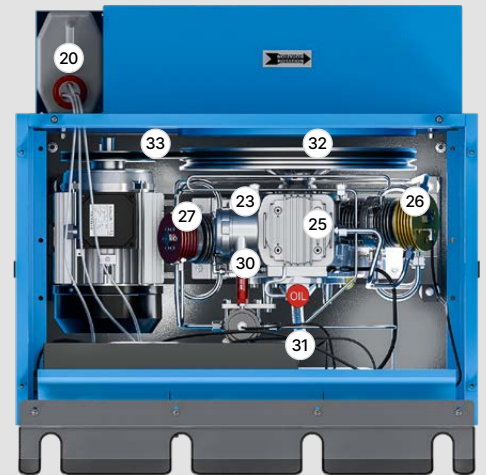

Machine parts

- | | | |
|--|--------------------------------|----------------------------|
| 1 Frame | 12 3rd stage pressure gauge | 24 LP condensate separator |
| 2 Control panel | 13 2nd stage pressure gauge | 25 1st stage |
| 3 ON pushbutton | 14 1st stage pressure gauge | 26 2nd stage |
| 4 Stop pushbutton | 15 Refill hoses connection | 27 3rd stage |
| 5 Condensate discharge pushbutton | 16 Condensate discharge valves | 28 Monobloc |
| 6 Oil level warning light | 17 Oil level | 29 Oil filler plug |
| 7 Direction of rotation indicator light | 18 Oil discharge valves | 30 Safety valve |
| 8 Hour counter | 19 Purification system | 31 Maintenance valve |
| 9 Cabinet interior / cooling air temperature | 20 Condensate collection can | 32 Cooling fan |
| 10 Emergency pushbutton | 21 Electric motor | 33 Belt |
| 11 Automatic shutdown pressure switch | 22 Pumping unit | 34 HP condensate separator |
| | 23 Air filter | |

Prime line

Mark III Silent TPS

Electric



Mark III Silent
TPS 210 EM¹

Mark III Silent
TPS 235 ET

Mark III Silent
TPS 315 ET

Mark III Silent
TPS 345 ET

Mark III Silent
TPS 380 ET

Charging rate

210 l/min

235 l/min

315 l/min

345 l/min

380 l/min

Refill time²

10 min

8.30 min

6.20 min

5.40 min

5.15 min

Engine power

4 kW

4 kW

5,5 kW

7,5 kW

7,5 kW

Single-phase electric

Three-phase electric

Three-phase electric

Three-phase electric

Three-phase electric

¹ Data referred to the maximum pressure of 232 bar

² Filling time 10 l empty cylinder - 0/200 bar (tolerance ±5%)

No compromise.

The **Mark III Silent TPS** range is ideal for intensive use in hot, poorly ventilated environments or in tropical countries. Designed with an improved cooling system and a filtering system with two Hyperfilters, these compressors are powered by an electric motor and equipped with four different pumping units, all in TPS (Tropical Plus Superdry) version. They are available with function monitoring systems and electrical panel for automatic compressor shutdown.

Working pressure from 232 to 420 bar

Standard equipment

1	2 filling connections to choose between (1a) DIN 232, (1b) DIN 300 o (1c) INT/YOKE 232 bar	7	Phase controller that prohibits reverse rotation
2	2 filling hoses of 1.2 m length	8	Electronic pressure switch with automatic switch-off
3	Pressure maintaining valve	9	Oil sight glass
4	Interstage control gauges	10	Oil pump with filter and pressure gauge
5	Double filtering system Hyperfilter certified PED	11	Auto-drain Condensate System with condensate collection tank
6	Automatic condensate drain	12	Frame color Blu RAL 5002

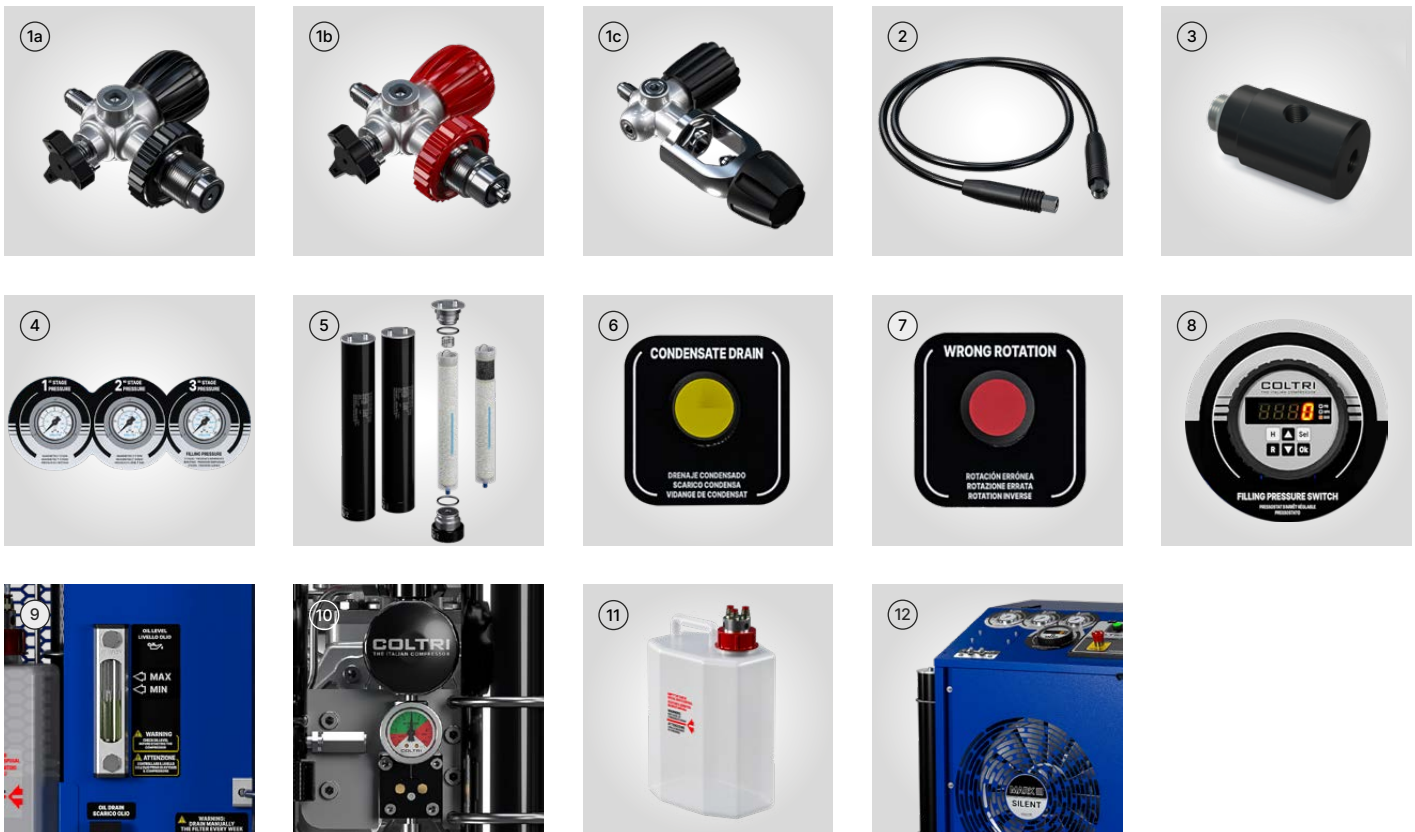

Optional

- 1 C-Monitor

- 2 Remote filling panel single pressure
(chosen from DRV DIN 232 bar, DRV DIN 300 bar or DRV INT/YOKE 232 bar)

- 3 Remote filling panel double pressure
(chosen from DRV DIN 232 bar + DRV DIN 300 bar or DRV INT/YOKE 232 bar + DRV DIN 300 bar). Including Priority Panel.

- 4 Remote filling panel single pressure with lever taps
(chosen from DRV DIN 232 bar, DRV DIN 300 bar or DRV INT/YOKE 232 bar)

- 5 Remote filling panel double pressure with lever taps
(chosen from DRV DIN 232 bar + DRV DIN 300 bar or DRV INT/YOKE 232 bar + DRV DIN 300 bar). Including Priority Panel.

- 6 Filling connection with gauge DRV DIN 232 bar

- 7 Filling connection with gauge DRV DIN 300 bar

- 8 DIN/INT adapter

- 9 Filling connection DRV DIN/INT

- 10 Presec, filter control system

- 11 SAM sensors CO + CO2 + H2O
Available in version with VOC.

- 12 Filling hose. Available: 1,5 m - 2,0 m
3,0 m - 4,0 m - 5,0 m - 8,0 m - 10,0 m

- 13 Stainless steel frame with MOQ

- 14 Purification system MEGAFILTER



Dimensions

Width 108 cm (42.5")
 Depth 86,5 cm (34.0")
 Height 91,5 cm (36.0")

Dry weight

- MARK III SILENT TPS 210 EM**
181 kg (399 lb)
- MARK III SILENT TPS 235 ET**
181 kg (399 lb)
- MARK III SILENT TPS 315 ET**
191 kg (421 lb)
- MARK III SILENT TPS 345 ET**
191 kg (421 lb)
- MARK III SILENT TPS 380 ET**
191 kg (421 lb)

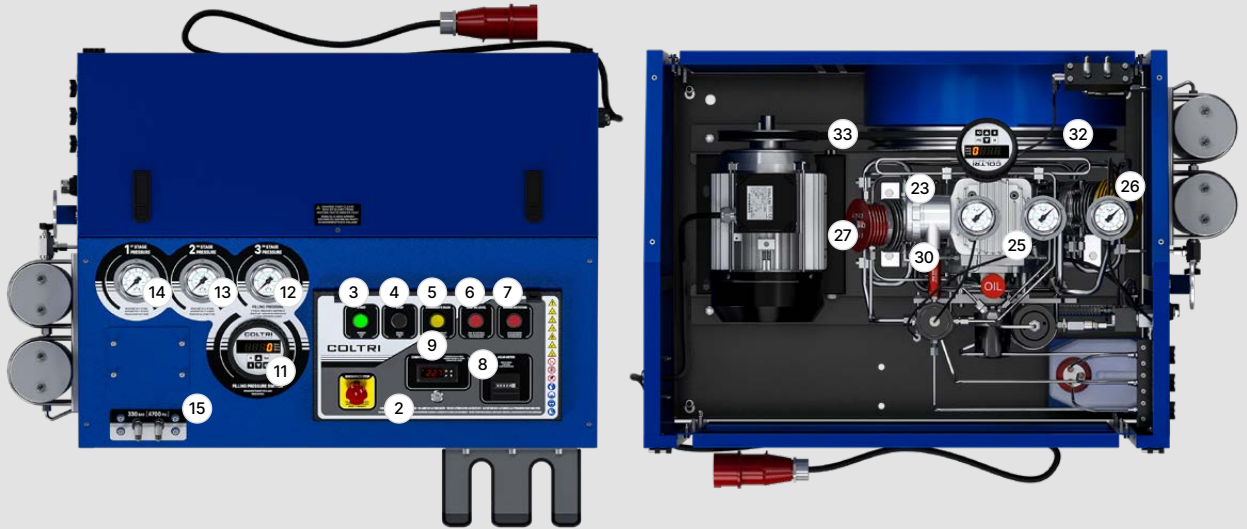
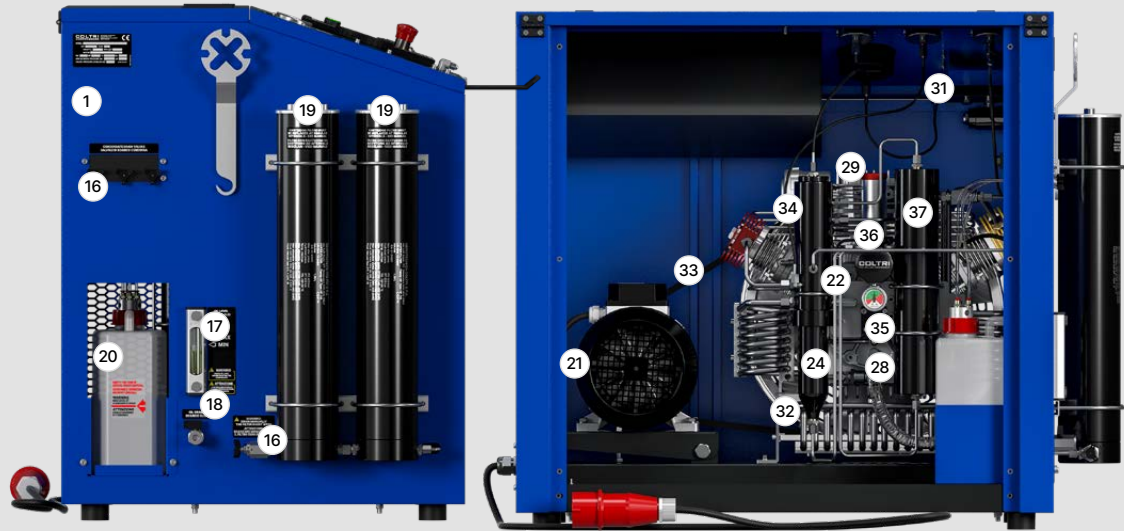

Machine parts

- | | | |
|--|--------------------------------|--|
| 1 Frame | 13 2nd stage pressure gauge | 26 2nd stage |
| 2 Control panel | 14 1st stage pressure gauge | 27 3rd stage |
| 3 ON pushbutton | 15 Refill hoses connection | 28 Monobloc |
| 4 Stop pushbutton | 16 Condensate discharge valves | 29 Oil filler plug |
| 5 Condensate discharge pushbutton | 17 Oil level | 30 Safety valve |
| 6 Oil level warning light | 18 Oil discharge valves | 31 Maintenance valve |
| 7 Direction of rotation indicator light | 19 Purification system | 32 Cooling fan |
| 8 Hour counter | 20 Condensate collection can | 33 Belt |
| 9 Cabinet interior / cooling air temperature | 21 Electric motor | 34 HP condensate separator |
| 10 Emergency pushbutton | 22 Pumping unit | 35 Oil pump |
| 11 Automatic shutdown pressure switch | 23 Air filter | 36 Oil filter |
| 12 3rd stage pressure gauge | 24 LP condensate separator | 37 HP High Efficiency condensate separator |
| | 25 1st stage | |

Prime line

Ergo TPS

Electric



Ergo TPS
235 ET

Ergo TPS
270 EM¹

Ergo TPS
315 ET

Ergo TPS
345 ET

Ergo TPS
380 ET

Charging rate

235 l/min

270 l/min

315 l/min

345 l/min

380 l/min

Refill time²

8.30 min

7.20 min

6.20 min

5.40 min

5.15 min

Engine power

4 kW

Three-phase electric

5,5 kW

Single-phase electric

5,5 kW

Three-phase electric

7,5 kW

Three-phase electric

7,5 kW

Three-phase electric

¹ Data referred to the maximum pressure of 300 bar

² Filling time 10 l empty cylinder - 0/200 bar (tolerance ±5%)

Less is more.

ERGO TPS is the best solution for those who want a compact breathing air compressor without compromising on high performance. Equipped with four different TPS (Tropical Plus Superdry) pumping units, ERGO TPS is powered by electric motors or engines (Honda for the petrol version, Kohler for the diesel compressors). It has a panel with a monitoring system complete with pressure gauges, autostop with adjustable electronic pressure switch, automatic condensate drain and rotation direction control. It also has two connections for high pressure hoses and an improved filtering system with two Hyperfilters. The remote charging panel is available as an option.

Working pressure from 232 to 420 bar

Standard equipment

- 1 2 filling connections to choose between (1a) DIN 232, (1b) DIN 300 o (1c) INT/YOKE 232 bar
- 2 2 filling hoses of 1.2 m length
- 3 Pressure maintaining valve
- 4 Interstage control gauges
- 5 Double filtering system Hyperfilter certified PED
- 6 Cabin temperature with automatic switch-off
- 7 Automatic condensate drain

- 8 Phase controller that prohibits reverse rotation
- 9 Electronic pressure switch with automatic switch-off
- 10 Oil sight glass
- 11 Oil pump with filter and pressure gauge
- 12 Auto-drain Condensate System with condensate collection tank
- 13 Carrying handles
- 14 Frame color Blue RAL 5002

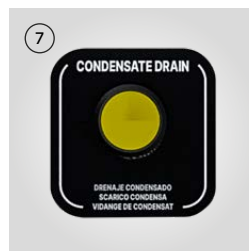
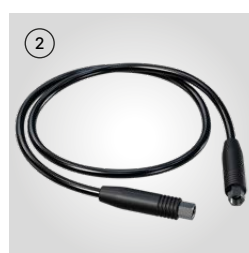

Optional

- 1 C-Monitor

- 2 Remote filling panel single pressure
(chosen from DRV DIN 232 bar, DRV DIN 300 bar or DRV INT/YOKE 232 bar)

- 3 Remote filling panel double pressure
(chosen from DRV DIN 232 bar + DRV DIN 300 bar or DRV INT/YOKE 232 bar + DRV DIN 300 bar). Including Priority Panel.

- 4 Remote filling panel single pressure with lever taps
(chosen from DRV DIN 232 bar, DRV DIN 300 bar or DRV INT/YOKE 232 bar)

- 5 Remote filling panel double pressure with lever taps
(chosen from DRV DIN 232 bar + DRV DIN 300 bar or DRV INT/YOKE 232 bar + DRV DIN 300 bar). Including Priority Panel.

- 6 Filling connection with gauge DRV DIN 232 bar

- 7 Filling connection with gauge DRV DIN 300 bar

- 8 DIN/INT adapter

- 9 Filling connection DRV DIN/INT

- 10 Presec, filter control system

- 11 Filling hose. Available: 1,5 m - 2,0 m
3,0 m - 4,0 m - 5,0 m - 8,0 m - 10,0 m

- 12 Wheel kit

- 13 Stainless steel frame with MOQ



Dimensions

Width 112 cm (44.1")

Depth 63 cm (24.8")

Height 77 cm (30.3")

Dry weight

ERGO TPS 235 ET

174 kg (384 lb)

ERGO TPS 270 EM / ERGO TPS 315 ET

184 kg (406 lb)

ERGO TPS 345 ET / ERGO TPS 380 ET

184 kg (406 lb)

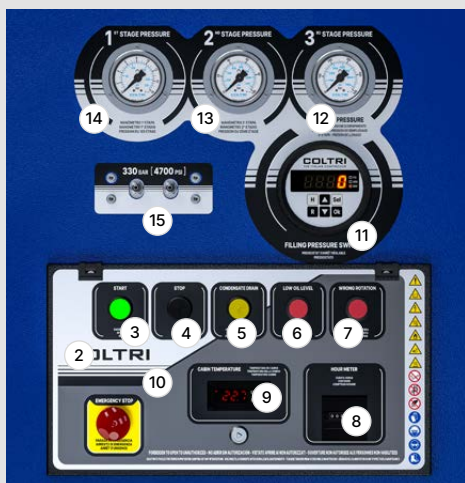
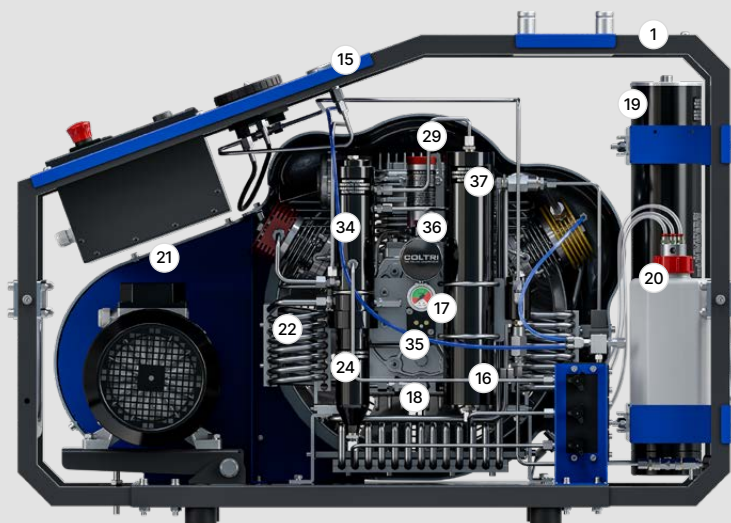

Machine parts

- | | | | | | |
|----|--|----|-----------------------------|----|---|
| 1 | Frame | 13 | 2nd stage pressure gauge | 26 | 2nd stage |
| 2 | Control panel | 14 | 1st stage pressure gauge | 27 | 3rd stage |
| 3 | ON pushbutton | 15 | Refill hoses connection | 28 | Monobloc |
| 4 | Stop pushbutton | 16 | Condensate discharge valves | 29 | Oil filler plug |
| 5 | Condensate discharge pushbutton | 17 | Oil level | 30 | Safety valve |
| 6 | Oil level warning light | 18 | Oil discharge valves | 31 | Maintenance valve |
| 7 | Direction of rotation indicator light | 19 | Purification system | 32 | Cooling fan |
| 8 | Hour counter | 20 | Condensate collection can | 33 | Belt |
| 9 | Cabinet interior / cooling air temperature | 21 | Electric motor | 34 | HP condensate separator |
| 10 | Emergency pushbutton | 22 | Pumping unit | 35 | Oil pump |
| 11 | Automatic shutdown pressure switch | 23 | Air filter | 36 | Oil filter |
| 12 | 3rd stage pressure gauge | 24 | LP condensate separator | 37 | HP High Efficiency condensate separator |
| | | 25 | 1st stage | | |

Prime line

Super Silent TPS

Electric

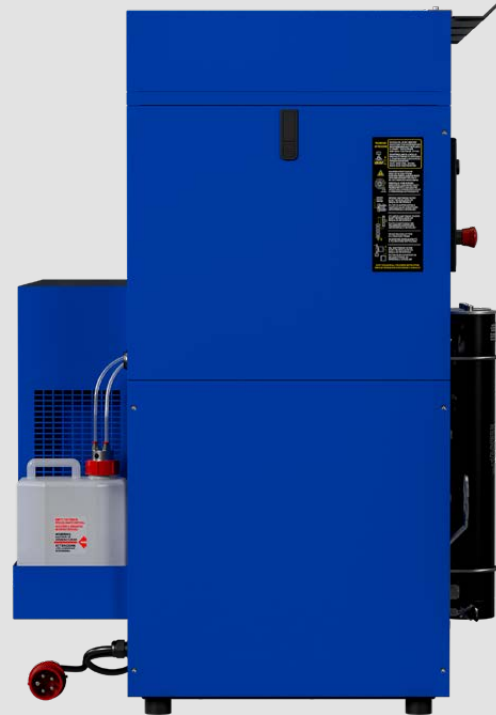

**Super Silent
TPS 235 ET**

**Super Silent
TPS 315 ET**

**Super Silent
TPS 345 ET**

**Super Silent
TPS 380 ET**

Charging rate

235 l/min

315 l/min

345 l/min

380 l/min

Refill time ¹

8.30 min

6.20 min

5.40 min

5.15 min

Engine power

4 kW

Three-phase electric

5,5 kW

Three-phase electric

7,5 kW

Three-phase electric

7,5 kW

Three-phase electric

¹ Filling time 10 l empty cylinder - 0/200 bar (tolerance ±5%)

Listen to its absolute silence.

The **SUPER SILENT TPS** model is specifically designed to minimise noise. It features an enhanced cooling and sound insulation system and an efficient filtering system with two Hyperfilters. Powered by an electric motor, it has four different pumping units, all in the TPS (Tropical Plus Superdry) version, and an intuitive control panel. For longer filter life, we recommend the Tornado high pressure dryer.

Working pressure from 232 to 420 bar

Standard equipment

1	2 filling connections to choose between (1a) DIN 232, (1b) DIN 300 o (1c) INT/YOKE 232 bar	8	Phase controller that prohibits reverse rotation
2	2 filling hoses of 1.2 m length	9	Electronic pressure switch with automatic switch-off
3	Pressure maintaining valve	10	Oil sight glass
4	Interstage control gauges	11	Oil pump with filter and pressure gauge
5	Double filtering system Hyperfilter certified PED	12	Auto-drain Condensate System with condensate collection tank
6	Cabin temperature with automatic switch-off	13	Frame color Blu RAL 5002
7	Automatic condensate drain		

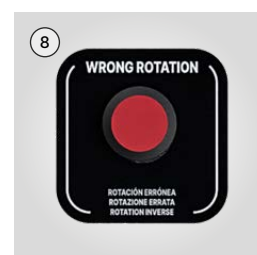
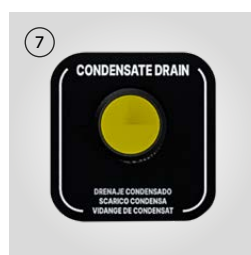

Optional

- 1 Remote filling panel single pressure
(chosen from DRV DIN 232 bar, DRV DIN 300 bar or DRV INT/YOKE 232 bar)

- 2 Remote filling panel double pressure
(chosen from DRV DIN 232 bar + DRV DIN 300 bar or DRV INT/YOKE 232 bar + DRV DIN 300 bar). Including Priority Panel.

- 3 Remote filling panel single pressure with lever taps
(chosen from DRV DIN 232 bar, DRV DIN 300 bar or DRV INT/YOKE 232 bar)

- 4 Remote filling panel double pressure with lever taps
(chosen from DRV DIN 232 bar + DRV DIN 300 bar or DRV INT/YOKE 232 bar + DRV DIN 300 bar). Including Priority Panel.

- 5 Filling connection with gauge DRV DIN 232 bar

- 6 Filling connection with gauge DRV DIN 300 bar

- 7 DIN/INT adapter

- 8 Filling connection DRV DIN/INT

- 9 Presec, filter control system

- 10 SAM sensors CO + CO2 + H2O
Available in version with VOC.

- 11 Tornado refrigerator - Dryer
Available in 350 bar or 420 bar versions.

- 12 Filling hose. Available: 1,5 m - 2,0 m
3,0 m - 4,0 m - 5,0 m - 8,0 m - 10,0 m

- 13 Stainless steel frame with MOQ



Dimensions

Width 90 cm (35.4")
 Depth 93 cm (36.6")
 Height 132 cm (52")

Dry weight

SUPER SILENT TPS 235 ET
 212 kg (467 lb)
SUPER SILENT TPS 315 ET
SUPER SILENT TPS 345 ET
SUPER SILENT TPS 380 ET
 222 kg (489 lb)

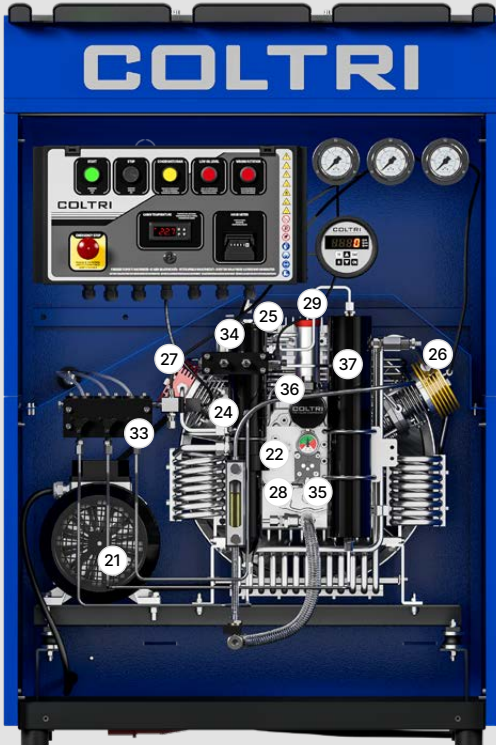

Machine parts

- | | | |
|--|--------------------------------|--|
| 1 Telaio | 13 2nd stage pressure gauge | 25 1st stage |
| 2 Control pannel | 14 1st stage pressure gauge | 26 2nd stage |
| 3 ON pushbutton | 15 Refill hoses connection | 27 3rd stage |
| 4 Stop pushbutton | 16 Condensate discharge valves | 28 Monobloc |
| 5 Condensate discharge pushbutton | 17 Oil level | 29 Oil filler plug |
| 6 Oil level warning light | 18 Oil discharge valves | 30 Safety valve |
| 7 Direction of rotation indicator light | 19 Purifier filter | 31 Maintenance valve |
| 8 Hour counter | 20 Condensate collection can | 32 Cooling fan |
| 9 Cabinet interior / cooling air temperature | 21 Motor | 33 Belt |
| 10 Emergency pushbutton | 22 Compressor | 34 HP condensate separator |
| 11 Automatic shutdown pressure switch | 23 Air filter | 35 Oil pump |
| 12 3rd stage pressure gauge | 24 LP condensate separator | 36 Oil filter |
| | | 37 HP High Efficiency condensate separator |

Heavy Duty line

Force Four

Electric

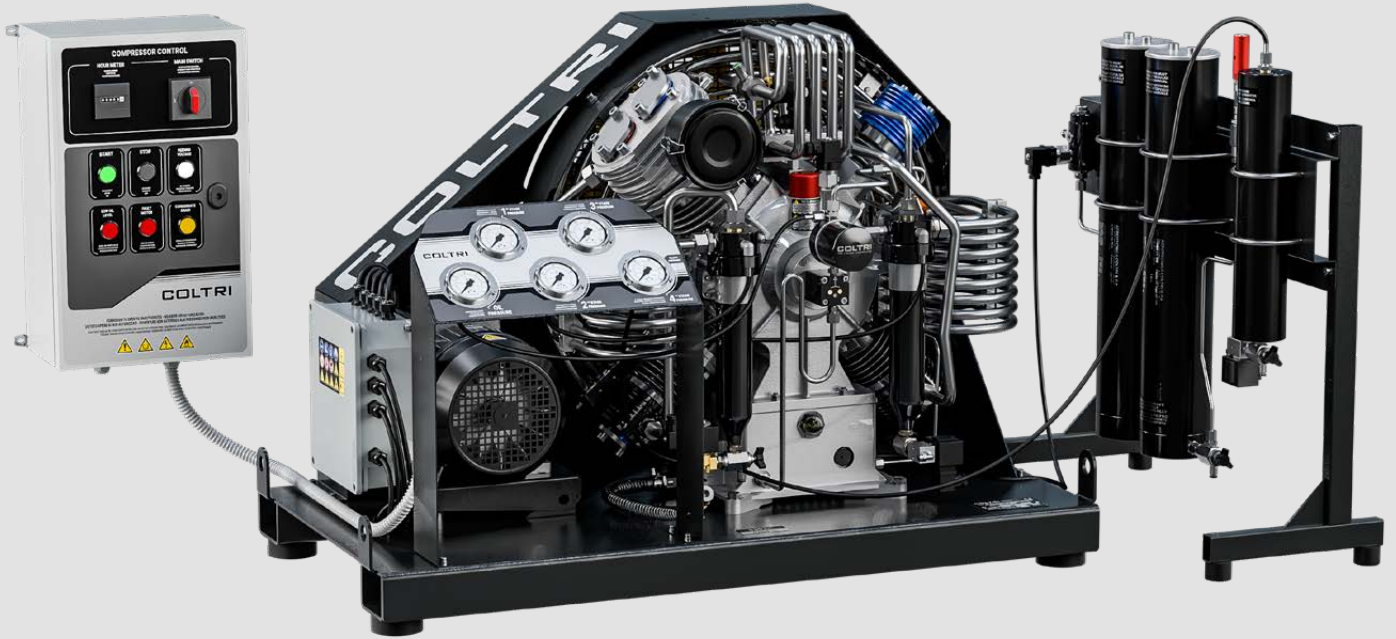

Open 400 EM¹

Open 450 ET

Open 550 ET

Open 650 ET

Charging rate

400 l/min

450 l/min

550 l/min

650 l/min

Refill time²

5 min

4.30 min

4 min

3 min

Engine power

7,5 kW

Single-phase electric

7,5 kW

Three-phase electric

9 kW

Three-phase electric

11 kW

Three-phase electric

¹ Data referred to the maximum pressure of 300 bar

² Filling time 10 l empty cylinder - 0/200 bar (tolerance ±5%)

It goes out of its way to give you the best.

The FORCE FOUR model meets professional needs that require large charging capacities in hot, poorly ventilated environments or tropical countries. It is equipped with an intuitive control panel and electric motor. The pumping unit, a choice of 4 most powerful, is exposed to ensure a better cooling cycle. It is equipped with the Hyperfilter purification system mounted on a stand-alone system, with automatic condensate drainage. For longer filter life, the Tornado high-pressure dryer is recommended. Available as options: the Presec system for filter saturation control, Megafilter oversized filter cartridges, and 2- or 4-outlet remote refill panel.

Working pressure from 232 to 420 bar

Standard equipment

- 1 4 filling connections to choose between (1a) DIN 232, (1b) DIN 300 o (1c) INT/YOKE 232 bar
- 2 4 filling hoses of 1.2 m length
- 3 Pressure maintaining valve
- 4 Interstage control gauges
- 5 Double filtering system Hyperfilter certified PED

- 6 Purification system on "stand-alone" structure
- 7 Automatic condensate drain
- 8 Oil sight glass
- 9 Oil pump
- 10 Frame color Black RAL 9005



Optional

- | | | | |
|---|--|----|--|
| 1 | Remote filling panel single pressure
(chosen from DRV DIN 232 bar, DRV DIN 300 bar or DRV INT/YOKE 232 bar) | 6 | Filling connection with gauge DRV DIN 300 bar |
| 2 | Remote filling panel double pressure
(chosen from DRV DIN 232 bar + DRV DIN 300 bar or DRV INT/YOKE 232 bar + DRV DIN 300 bar). Including Priority Panel. | 7 | DIN/INT adapter |
| 3 | Remote filling panel single pressure with lever taps
(chosen from DRV DIN 232 bar, DRV DIN 300 bar or DRV INT/YOKE 232 bar) | 8 | Filling connection DRV DIN/INT |
| 4 | Remote filling panel double pressure with lever taps
(chosen from DRV DIN 232 bar + DRV DIN 300 bar or DRV INT/YOKE 232 bar + DRV DIN 300 bar). Including Priority Panel. | 9 | Presec, filter control system |
| 5 | Filling connection with gauge DRV DIN 232 bar | 10 | Purification system MEGAFILTER |
| | | 11 | Tornado refrigerator - Dryer
Available in 350 bar or 420 bar versions. |
| | | 12 | Filling hose. Available: 1,5 m - 2,0 m
3,0 m - 4,0 m - 5,0 m - 8,0 m - 10,0 m |
| | | 13 | Stainless steel frame with MOQ |



Dimensions

Width 115 cm (45.3")
 Depth 60 cm (23.6")
 Height 45.3 cm (31.3")

Dry weight

FORCE FOUR 400 EM 250 kg (551 lb)
 Without filter system
FORCE FOUR 450 ET 250 kg (551 lb)
 Without filter system
FORCE FOUR 550 ET 250 kg (551 lb)
 Without filter system
FORCE FOUR 650 ET 260 kg (573 lb)
 Without filter system

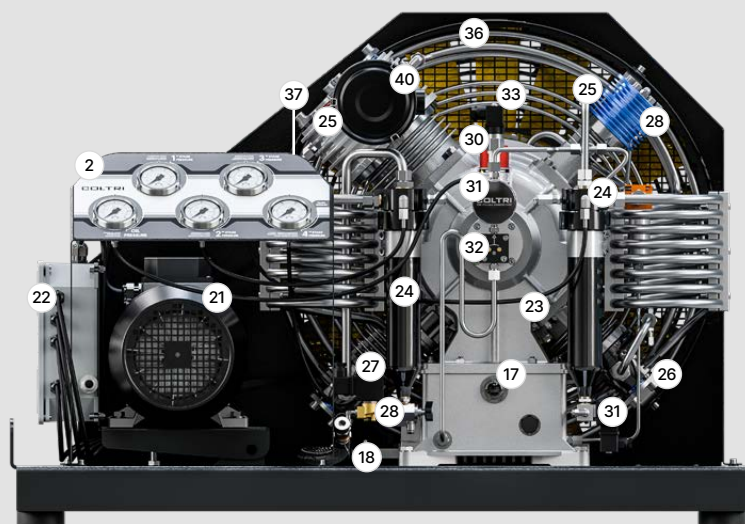
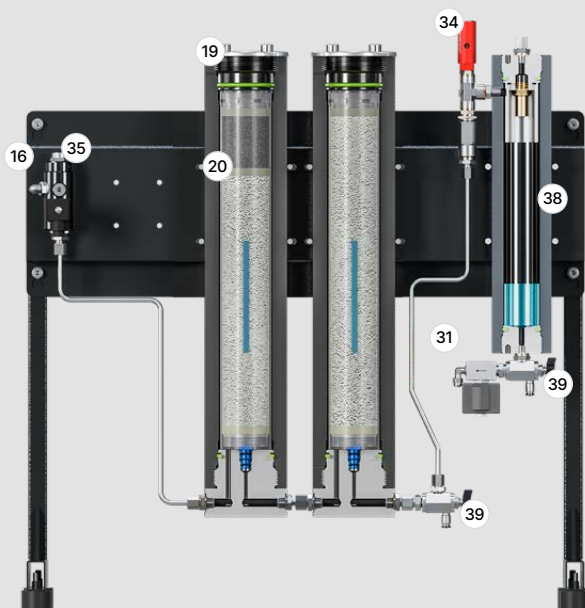
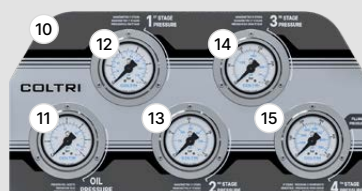

Machine parts

- | | | |
|---|---|-------------------------------------|
| 1 Control panel | 15 4 th stage pressure gauge | 29 Condensate discharge valve |
| 2 Main switch | 16 Pressure gas/air outlet | 30 Oil filler plug |
| 3 ON switch | 17 Oil level | 31 Oil filter |
| 4 Stop pushbutton | 18 Oil discharge valves | 32 Oil pump |
| 5 Condensate discharge pushbutton | 19 Purification system | 33 Minimum oil pressure switch |
| 6 Power indicator light | 20 Filter cartridge Hyperfilter | 34 Safety valve |
| 7 Direction of rotation indicator light | 21 Electric motor | 35 Maintenance valve pressure |
| 8 Oil level warning light | 22 Electrical cabinet | 36 Cooling fan |
| 9 Hour meter | 23 Pumping unit | 37 Belt |
| 10 Control Panel | 24 Condensate separator | 38 Final condensate separator |
| 11 Oil pressure gauge | 25 1 st stage | 39 Circuit pressure discharge valve |
| 12 1 st stage pressure gauge | 26 2 nd stage | 40 Suction filter |
| 13 2 nd stage pressure gauge | 27 3 rd stage | |
| 14 3 rd stage pressure gauge | 28 4 th stage | |

Heavy Duty line

Open

Electric



Open 400 EM¹

Open 450 ET

Open 550 ET

Open 650 ET

Open 750 ET

Charging rate

400 l/min

450 l/min

550 l/min

650 l/min

750 l/min

Refill time²

5 min

4.30 min

4 min

3 min

2.40 min

Engine power

7,5 kW
Single-phase electric

7,5 kW
Three-phase electric

9 kW
Three-phase electric

11 kW
Three-phase electric

15 kW
Three-phase
electric

¹ Data referred to the maximum pressure of 300 bar

² Filling time 10 l empty cylinder - 0/200 bar (tolerance ±5%)

Top performance, even when charging.

The **OPEN** model meets professional needs that require large charging capacities in hot, poorly ventilated environments or tropical countries. It has 4 front filling connections for high pressure hoses, an intuitive control panel and an electric motor. The pumping group, chosen from the 4 most powerful, is exposed in the rear housing to ensure a better cooling cycle. For longer filter life, we recommend the Tornado high pressure dryer. Available option: Presec system for filter saturation control or the SAM system for multigas analysis and remote charging panel.

Working pressure from 232 to 420 bar

Standard equipment

1	4 filling connections to choose between (1a) DIN 232, (1b) DIN 300 o (1c) INT/YOKE 232 bar	8	Phase controller that prohibits reverse rotation
2	4 filling hoses of 1.2 m length	9	Electronic pressure switch with automatic switch-off
3	Pressure maintaining valve	10	Oil sight glass
4	Interstage control gauges	11	Oil pump
5	Double filtering system Hyperfilter certified PED	12	Auto-drain Condensate System with condensate collection tank
6	Cabin temperature with automatic switch-off	13	Frame color Black RAL 9005
7	Automatic condensate drain		

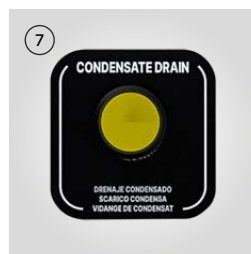
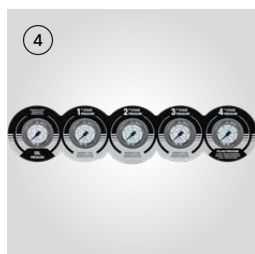
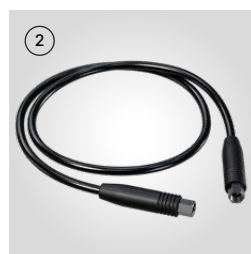

Optional

- | | | | |
|---|--|----|--|
| 1 | Remote filling panel single pressure
(chosen from DRV DIN 232 bar, DRV DIN 300 bar or DRV INT/YOKE 232 bar) | 7 | DIN/INT adapter |
| 2 | Remote filling panel double pressure
(chosen from DRV DIN 232 bar + DRV DIN 300 bar or DRV INT/YOKE 232 bar + DRV DIN 300 bar). Including Priority Panel. | 8 | Filling connection DRV DIN/INT |
| 3 | Remote filling panel single pressure with lever taps
(chosen from DRV DIN 232 bar, DRV DIN 300 bar or DRV INT/YOKE 232 bar) | 9 | Presec, filter control system |
| 4 | Remote filling panel double pressure with lever taps
(chosen from DRV DIN 232 bar + DRV DIN 300 bar or DRV INT/YOKE 232 bar + DRV DIN 300 bar). Including Priority Panel. | 10 | SAM sensors CO + CO2 + H2O
Available in version with VOC. |
| 5 | Filling connection with gauge DRV DIN 232 bar | 11 | Tornado refrigerator - Dryer
Available in 350 bar or 420 bar versions. |
| 6 | Filling connection with gauge DRV DIN 300 bar | 12 | Touch screen |
| | | 13 | Filling hose. Available: 1,5 m - 2,0 m
3,0 m - 4,0 m - 5,0 m - 8,0 m - 10,0 m |
| | | 14 | Stainless steel frame with MOQ |



Dimensions

Width 90,5 cm (35.6")
 Depth 105,2 cm (60.2")
 Height 153 cm (41.4")

Dry weight

OPEN 450 EM 356 kg (784 lb)
 OPEN 450 ET 356 kg (784 lb)
 OPEN 550 ET 361 kg (796 lb)

OPEN 650 ET 365 kg (804 lb)
 OPEN 760 ET 373 kg (943 lb)

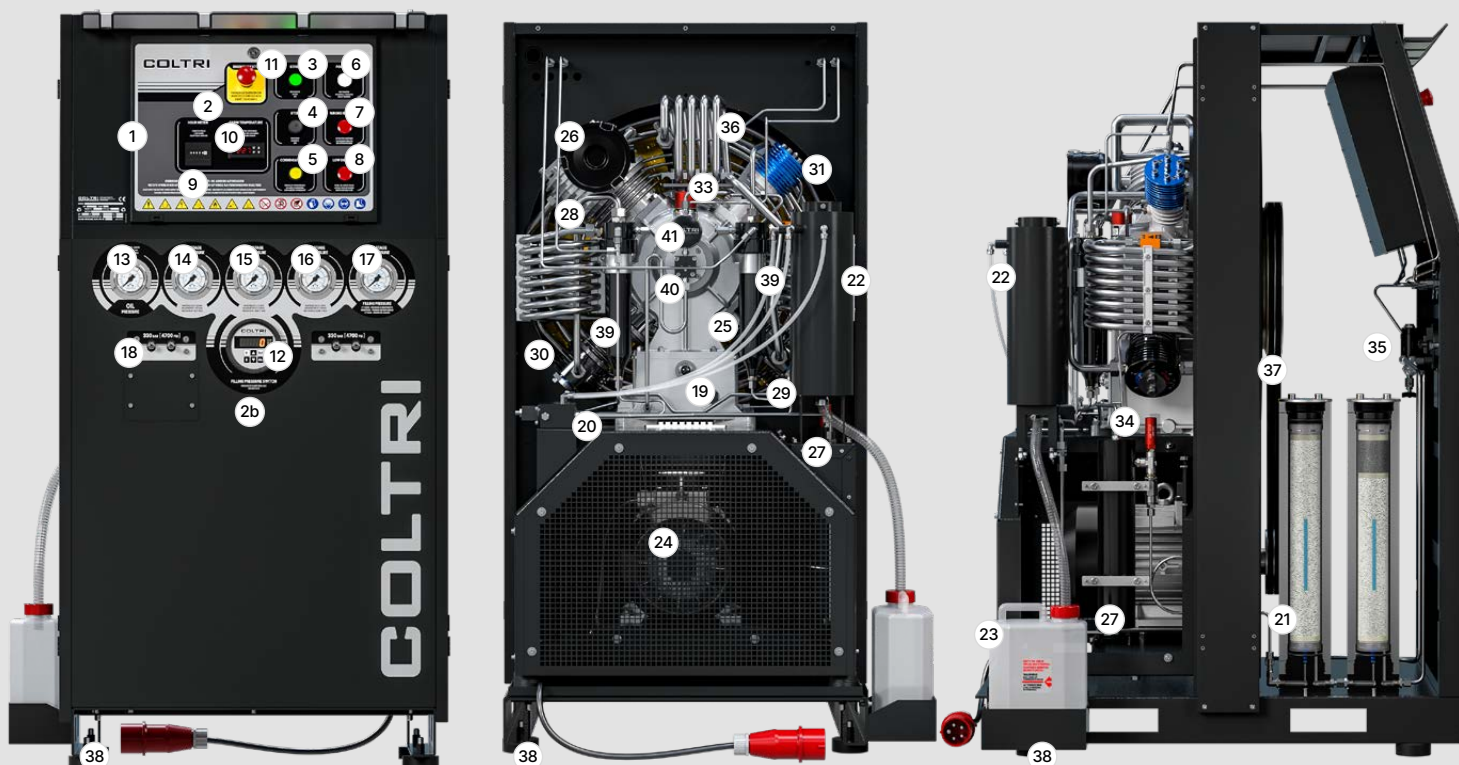

Machine parts

- | | | | | | |
|----|--|----|---|----|-----------------------|
| 1 | Frame | 14 | 1st stage pressure gauge | 28 | 1st stage |
| 2 | Control panel | 15 | 2nd stage pressure gauge | 29 | 2nd stage |
| 3 | ON pushbutton | 16 | 3rd stage pressure gauge | 30 | 3rd stage |
| 4 | Stop pushbutton | 17 | 4th stage pressure gauge / working pressure | 31 | 4th stage |
| 5 | Condensate discharge pushbutton | 18 | Refill hoses connection | 32 | Monoblock |
| 6 | Power indicator light | 19 | Oil level | 33 | Oil filler plug |
| 7 | Direction of rotation indicator light | 20 | Oil discharge valves | 34 | Safety valve |
| 8 | Oil level warning light | 21 | Purification system | 35 | Maintenance valve |
| 9 | Hour counter | 22 | Condensate collection container | 36 | Cooling fan |
| 10 | Cabinet interior / cooling air temperature | 23 | Condensate collection tank | 37 | Belt |
| 11 | Emergency pushbutton | 24 | Electric motor | 38 | Anti-vibration device |
| 12 | Automatic shutdown pressure switch | 25 | Pumping unit | 39 | Condensate separator |
| 13 | Oil pressure gauge | 26 | Air filter | 40 | Oil pump |
| | | 27 | Final condensate separator | 41 | Oil filter |

Heavy Duty line

Silent

Electric



Silent 400 EM¹

Silent 450 ET

Silent 550 ET

Silent 650 ET

Silent 750 ET

Charging rate

400 l/min

450 l/min

550 l/min

650 l/min

750 l/min

Refill time²

5 min

4.30 min

4 min

3 min

2.40 min

Engine power

7,5 kW

Single-phase electric

7,5 kW

Three-phase electric

9 kW

Three-phase electric

11 kW

Three-phase electric

15 kW

Three-phase electric

¹ Data referred to the maximum pressure of 300 bar

² Filling time 10 l empty cylinder - 0/200 bar (tolerance ±5%)

What you don't feel is his greatest performance.

The **SILENT** model reaches new heights in terms of soundproofing, falling below the 70 dB operating threshold. Built to meet the demands of intensive use when large refill capacities are required, it has 4 front filling connections with high pressure hoses and an intuitive control panel. It also has an electric motor and powerful pumping units. For longer filter life, we recommend the Tornado high pressure dryer. Available option: Presec system for filter saturation control or the SAM system for multigas analysis and remote charging panel.

Working pressure from 232 to 420 bar

Standard equipment

1	4 filling connections to choose between (1a) DIN 232, (1b) DIN 300 o (1c) INT/YOKE 232 bar	8	Phase controller that prohibits reverse rotation
2	4 filling hoses of 1.2 m length	9	Electronic pressure switch with automatic switch-off
3	Pressure maintaining valve	10	Oil sight glass
4	Interstage control gauges	11	Oil pump
5	Double filtering system Hyperfilter certified PED	12	Auto-drain Condensate System with condensate collection tank
6	Cabin temperature with automatic switch-off	13	Frame color Black RAL 9005
7	Automatic condensate drain		

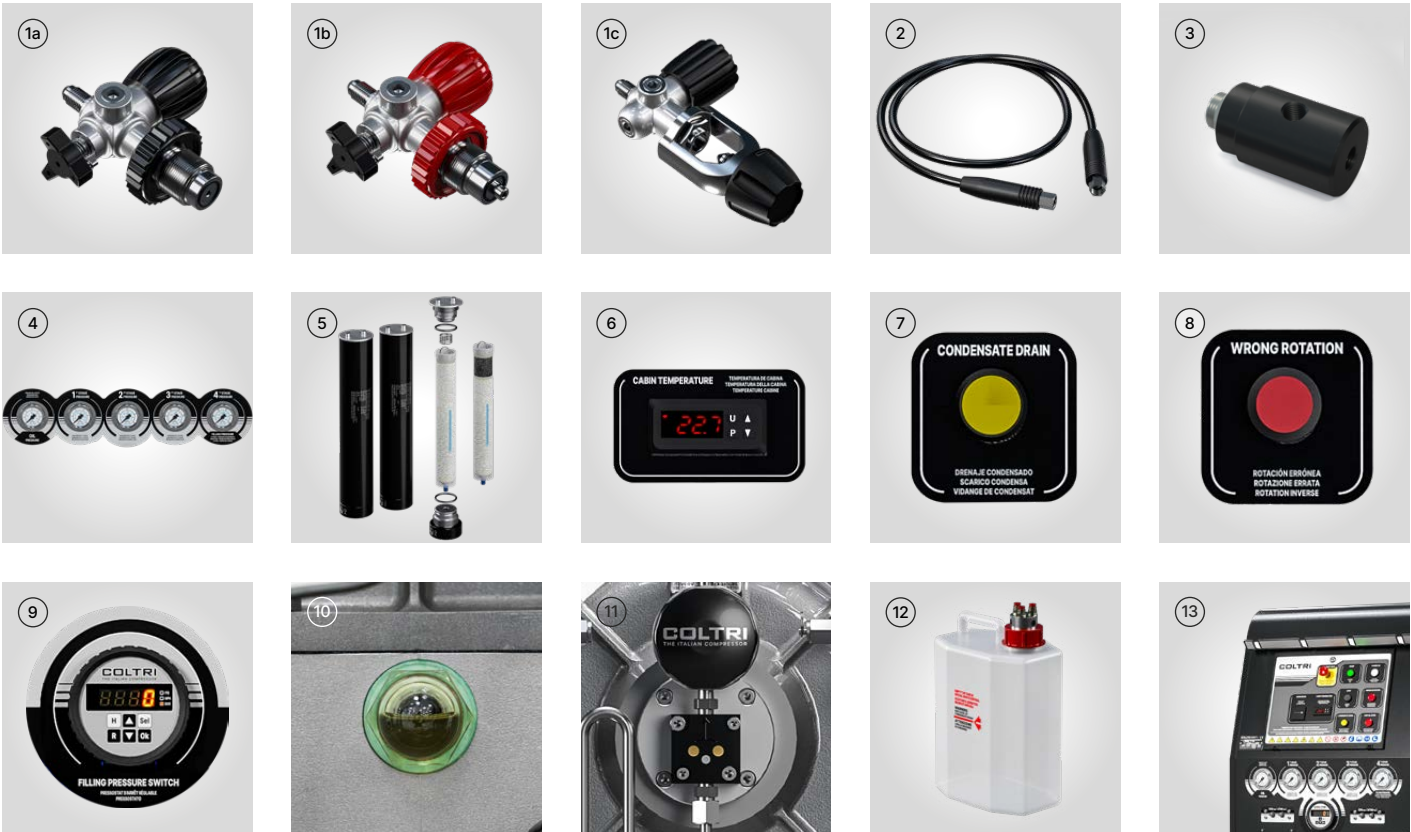

Optional

- | | | | |
|---|--|----|--|
| 1 | Remote filling panel single pressure
(chosen from DRV DIN 232 bar, DRV DIN 300 bar or DRV INT/YOKE 232 bar) | 7 | DIN/INT adapter |
| 2 | Remote filling panel double pressure
(chosen from DRV DIN 232 bar + DRV DIN 300 bar or DRV INT/YOKE 232 bar + DRV DIN 300 bar). Including Priority Panel. | 8 | Filling connection DRV DIN/INT |
| 3 | Remote filling panel single pressure with lever taps
(chosen from DRV DIN 232 bar, DRV DIN 300 bar or DRV INT/YOKE 232 bar) | 9 | Presec, filter control system |
| 4 | Remote filling panel double pressure with lever taps
(chosen from DRV DIN 232 bar + DRV DIN 300 bar or DRV INT/YOKE 232 bar + DRV DIN 300 bar). Including Priority Panel. | 10 | SAM sensors CO + CO2 + H2O
Available in version with VOC. |
| 5 | Filling connection with gauge DRV DIN 232 bar | 11 | Tornado refrigerator - Dryer
Available in 350 bar or 420 bar versions. |
| 6 | Filling connection with gauge DRV DIN 300 bar | 12 | Touch screen |
| | | 13 | Filling hose. Available: 1,5 m - 2,0 m
3,0 m - 4,0 m - 5,0 m - 8,0 m - 10,0 m |
| | | 14 | Stainless steel frame with MOQ |



Dimensions

Width 93,5 cm (36.8")
 Depth 130 cm (51.3")
 Height 173,5 cm (68.3")

Dry weight

SILENT 450 EM 446 kg (983 lb)
SILENT 450 ET 446 kg (983 lb)
SILENT 550 ET 451 kg (994 lb)

SILENT 650 ET 455 kg (1.003 lb)
SILENT 760 ET 463 kg (1.020 lb)

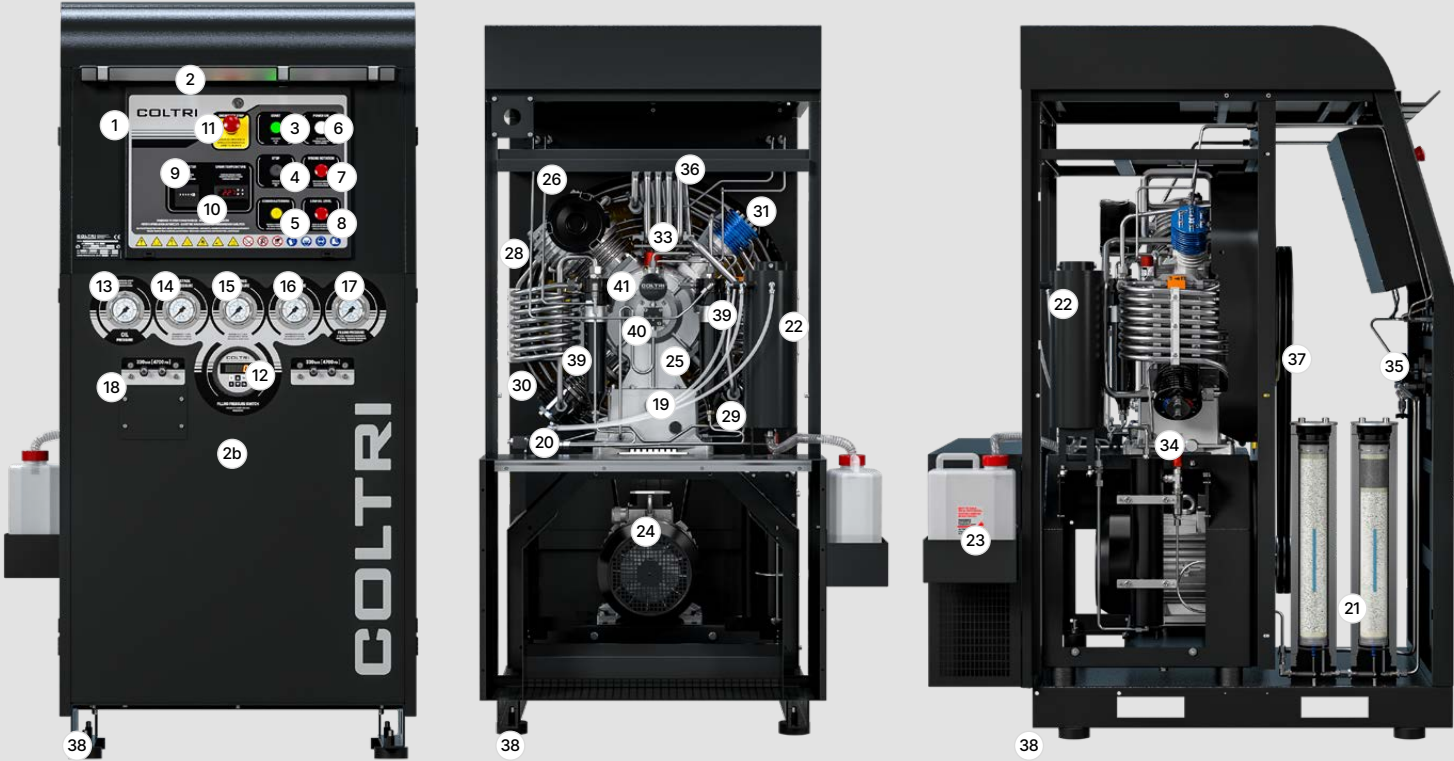

Machine parts

- 1 Frame
- 2 Control panel
- 3 ON pushbutton
- 4 Stop pushbutton
- 5 Condensate discharge pushbutton
- 6 Power indicator light
- 7 Direction of rotation indicator light
- 8 Oil level warning light
- 9 Hour counter
- 10 Cabinet interior / cooling air temperature
- 11 Emergency pushbutton
- 12 Automatic shutdown pressure switch
- 13 Oil pressure gauge
- 14 1st stage pressure gauge
- 15 2nd stage pressure gauge
- 16 3rd stage pressure gauge
- 17 4th stage pressure gauge / working pressure
- 18 Refill hoses connection
- 19 Oil level
- 20 Oil discharge valves
- 21 Purification system
- 22 Condensate collection container
- 23 Condensate collection tank
- 24 Electric motor
- 25 Pumping unit
- 26 Air filter
- 27 Final condensate separator
- 28 1st stage
- 29 2nd stage
- 30 3rd stage
- 31 4th stage
- 32 Monoblock
- 33 Oil filler plug
- 34 Safety valve
- 35 Maintenance valve
- 36 Cooling fan
- 37 Belt
- 38 Anti-vibration device
- 39 Condensate separator
- 40 Oil pump
- 41 Oil filter

Purification system

Purification system MAXIFILTER

Used on Efficient line models.

MAXIFILTER polypropylene cartridge repackable or disposable

Purification system	Maxifilter
Operating pressure (Standard)	232 bar / 330 bar / 360 bar
Operating pressure max. (PS)	420 bar
Processable air capacity (air inlet temperature in the filter 20° C at 300 bar) ¹	890 m ³

¹ When using a filter cartridge without HOPCALITE CO CATALYST.

When using a cartridge with CO-removal, the processable air capacity is reduced by ca. 20%.



Separator system

Used on Efficient line models.

- Interstage separator after 2nd stage ,stainless steel AISI 316.
- Final separator for the removal of oil/water condensate.
- Final safety valve, fitted to separator housing.
- Pressure maintaining/non return valve, fitted to filter bracket.

Contamination	Maximum content as per DIN EN 12021:2014	Air quality*
H ₂ O	25 mg/m ³	≤ 10 mg/m ³
CO	5 ppm(v)	≤ 4
CO ₂	500 ppm(v)	≤ 500
Oil	0,5 mg/m ³	≤ 0,5 mg/m ³

* Measured at our facility using ASCO HORA 160 ANALYZER.

¹ Only with special filter cartridge with HOPCALITE CO CATALYST. and up to a maximum concentration of 25 ppm CO in intake air. The compressed clean breathing air then contains a maximum of 5 ppm CO.

² The level of CO₂ in the intake air must not exceed the maximum level of CO₂ as per EN 12021:2014

³ Reported values exceed ISO 8573-1 standards.



Purification system HYPERFILTER

Used on Prime Line and Heavy Duty Line models.

DOUBLE HYPERFILTER regenerable or disposable cartridge

Purification system	Hyperfilter x 2
Operating pressure (Standard)	250 bar / 330 bar / 360 bar
Operating pressure max. (PS)	420 bar
Processable air capacity (air inlet temperature in the filter 20° C at 300 bar)¹	3.050 m ³

¹ When using a filter cartridge without HOPCALITE CO CATALYST.
When using a cartridge with CO-removal, the processable air capacity is reduced by ca. 20%.

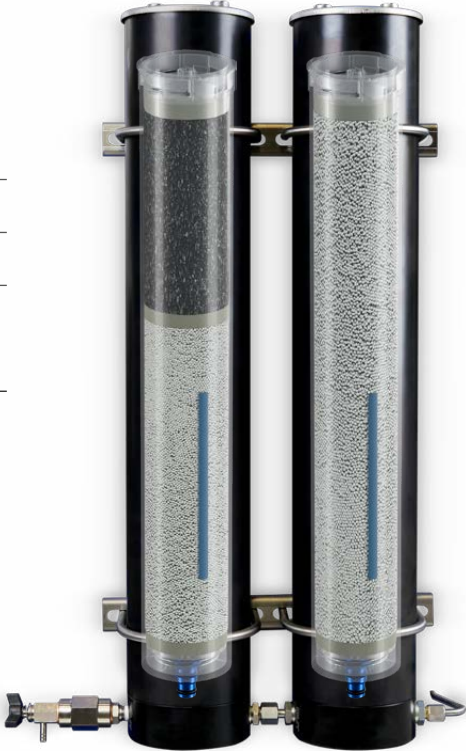

Separator system

Used on TPS Prime Line models.

- Interstage separator after 2nd stage, forged and anodized aluminum.
- Double final separator for removal of oil/water condensate
- Final safety valve, mounted on the separator housing
- Pressure maintenance valve / non-return valve

Contamination	Maximum content as per DIN EN 12021:2014	Air quality*
H ₂ O	25 mg/m ³	≤ 10 mg/m ³
CO	5 ppm(v)	≤ 4
CO ₂	500 ppm(v)	≤ 500
Oil	0,5 mg/m ³	≤ 0,5 mg/m ³

* Measured at our facility using ASCO HORA 160 ANALYZER.
¹ Only with special filter cartridge with HOPCALITE CO CATALYST. and up to a maximum concentration of 25 ppm CO in intake air.
 The compressed clean breathing air then contains a maximum of 5 ppm CO.
² The level of CO₂ in the intake air must not exceed the maximum level of CO₂ as per EN 12021:2014
³ Reported values exceed ISO 8573-1 standards.



MAXIFILTER cartridges



- A with molecular sieve and activated carbon
- B with molecular sieve
- C with activated carbon
- D with molecular sieve, activated carbon and CO-catalyst

Caps & discs kit for Maxifilter



Felts for Maxifilter

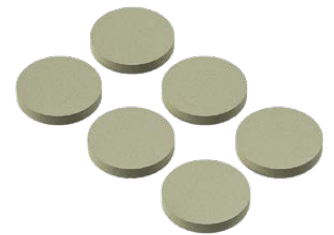

HYPERFILTER cartridges



- A with molecular sieve and activated carbon
- B with molecular sieve
- C with activated carbon
- D with molecular sieve, activated carbon and CO-catalyst
- E Hyperfilter cartridge Presec

Caps & discs kit for Hyperfilter



Felts for Hyperfilter

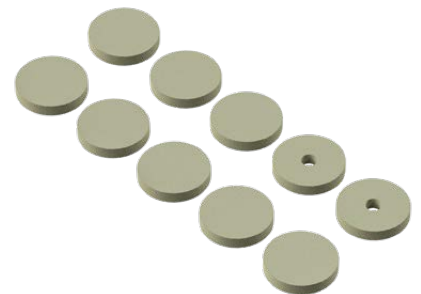

Synthetic Coltri Oil ST 755

A fully synthetic oil specifically developed for long lasting lubrication of process gas compressors and especially for breathing air. It provides outstanding performance in all types of compressors.



Activated carbon

Activated carbon is a material containing mainly **amorphous carbon**. Due to its high specific area, activated carbon is able to hold many molecules of other substances within it, being able to accommodate these molecules on its large internal surface area.



Molecular sieve

Molecular sieves are materials that can separate molecules based on size. This capability is based on the presence in the material of tiny pores of exact and uniform size, ranging in diameter from **3 to 10 Å** depending on the material.



CO catalyst

The trade name for a series of mixtures consisting primarily of copper and manganese oxides, used as catalysts for the conversion of carbon monoxide to carbon dioxide when exposed to oxygen in air at room temperature.



Standard equipment

Electromechanical pressure switch (Efficient)

Meter displays pressure in bar/psi. To be installed with existing Hyperfilter filter system on compressor.

Through the adjustment knob it allows to set the maximum pressure for automatic shutdown.



Digital pressure switch (TPS / HD)

The instrument allows to visualize the pressure expressed in bar, psi or MPa.

Through the programming buttons it allows to set the intervention pressure of the relay contact (SPDT) and hysteresis. The settings are protected by passwords at 3 levels: manufacturer, customer and end user. The instrument also has the function of Hour Meter for hours of operation and nr. cycles of separator intervention, ensuring a general improvement of the operation of the recharge station over time and the longevity of its filters. Standard equipment for Prime and HD lines.



According to EN 10204 Type 2.1

N.	Caratteristiche / Characteristics	Valori richiesti / requested values	Tolleranze / Tolerances	Strumento di controllo / Test equipment	Esito verifiche / Test Result
1	Setpoint alarm	300 bar	err.max 1,5% vfs	Elect. load 16V/10mA max	OK
2	Setpoint hysteresis	10 bar	err.max 1,5% vfs	Elect. load 16V/10mA max	OK
3	Range	0 – 400 bar	err.max 1,5% vfs	Pressure gauge cl. 0,25% vfs	OK
4	Process connection	G1/4"	Tab ISO228	Ring ISO228	OK

Standard equipment

Compressor control and automatic condensate drain system

- ON/OFF switch with motor protection switch.
- Optional: autostart at 60 bar hysteresis.
- Transformer.
- Pressure switch stops compressor at final pressure.
- Drainage of all separators between the individual stages and also of the final separator during compressor operation (standard drain interval every 8 minutes for a period of 6 seconds).
- Timer for automatic condensate drainage device.
- Integrated vacuum start-up (automatic drain when the unit is switched off).
- Condensate collection tank 5 liters, with silencer; capacity approx. 5 liters, for environmentally friendly disposal of condensate.
- Interstage pressure gauges display the operating pressure for the individual compression stages. This pressure information allows you to check the tightness of the valves (inlet and outlet) of each stage and quickly identify potential sources of failure.



The interstage pressure gauges are mounted in the compressor frame.



Optional

Tornado refrigerator - Dryer

Used on Heavy Duty and Super Silent TPS line.
Cooler, dryer for high pressure compressed air.

UP TO 3 TIMES LONGER FILTER SERVICE LIFE

- Higher air quality
- Less corrosion of mechanical parts
- Refilling of cylinders with constant percentage of humidity

The TORNADO refrigerator is an accessory for our recharge stations dedicated to professional use that operates between the separators and the filtering system. **Available in 350 or 420 bar versions.**

HOW TORNADO WORKS

The incoming warm, moist air passes into the evaporator of this machine, inside which it cools. This allows the moisture to condense. Condensation is then easily removed from the separator, ensuring an overall improvement in the operation of the charging station over time and the longevity of its filters.



Optional

Presec. Filter control system

Includes:

Filter cap with sensor + control unit + cartridge.

To be installed with the Hyperfilter filter system on compressor.

The Presec system is connected through a probe with the first filter cartridge and detects its saturation status transmitting to the indicator the relevant switching signals according to the status. If the filter cartridge is exhausted, the compressor is switched off and cannot be started until the cartridge is replaced.

The presec system displays 4 levels of cartridge saturation through 3 relays connected to 3 leds:

Stable green light (a):

- The system is operational; OK cartridge

Yellow light button (b):

- Pre-alarm; cartridge is running low and must be replaced soon.

Red light button (c):

- Alarm; remove cartridge, replace immediately.

Red light button (c):

- Alarm; filter cartridge is missing or filter system is interrupted; compressor shuts down and cannot be turned back on without inserting a new cartridge or discovering the source of the alarm.

While the yellow light is pulsing (b), the steady green light (a) will still be on because the filter cartridge will not be fully saturated.









If no LED lights up, it means that the PRESEC lacks power or that the electrical system is faulty.



Optional

C-Monitor

Final filter monitoring system, oil change and technical interface.

The interface consists of an LCD display, a button  and two indicators (, ). The decimal points next to the digits are indicator lights to indicate alarms or warnings in progress. Each dot is associated with an explanatory icon (, , ). The icon  indicates an alarm condition while the symbol  indicates normal operation. Press the button  to scroll through the different functions of the menu. When pressed, the function is displayed and after two 2 seconds the corresponding data is displayed.



Optional

Multi-Gas Analysis System (SAM)

Scegliendo il SAM Sistema Analisi Multigas non è possibile installare anche il sistema Presec.

The Coltri Multi-Gas Analysis System is a measuring instrument capable of monitoring air quality. Its application includes continuous monitoring of environmental gases, hyperbaric chambers, safety, medical, air quality.

Available sensors:

- Oxygen O₂
- Carbon dioxide CO₂
- Carbon Monoxide CO
- Humidity H₂O
- Gas Temperature
- VOC (Volatile Organic Compound)
- Helium in Air



General specifications

Input voltage requirement	10-35 Vdc
Internal Battery	Rechargeable lithium-ion battery. One cell 1400 mAh Li ion 3.7 V
Sensors	Up to 6 sensors
Output	Acoustic alarm
Serial Connection	1 RS232 interface. Transmission speed up to 115000 baud, on request RS485 interface
Measurement resolution	Bipolar 24-bit A/D converter. Drift in automatic temperature compensation.
Conversion rate	10 ms
Sampling time	100 ms (min) for each channel
Signal measurement accuracy	0.1% Full scale +/- 1/2 LSB
Input device	Rotary knob with central push
Color Display	TFT 320 x 240 dot resolution, LED backlighting
Display light intensity	600 nits (cd/m ²)
Memory	Micro SD card writer/reader
Microprocessor	Cortex M4

Nitrox line

LP Rotary Silent 250



Oxygen percentage

32% O₂

36% O₂

L/min.

315 l/min

235 l/min

Membrane type

Parker Enoxy SA 708 oxygen

LP Rotary Silent 250

It consists of an industrial screw compressor that delivers air at a pressure of 10 bar to the Parker® membrane. The percentage of oxygen obtained at the outlet can be adjusted from 28% to 38% thanks to a valve accessible on the front side of the compressor. When connected to a compressor with pumping unit 315 (MCH 16), 32% Nitrox can be obtained up to a pressure of 232 bar. The oxygen analyzer allows to verify the correct percentage, adjusting it through the appropriate valve.

Standard equipment

1	Electrical panel	4	Thermostat
2	Automatic condensate drain	5	1 Parker Enoxy SA 708 oxygen membrane
3	2 Analyzers		

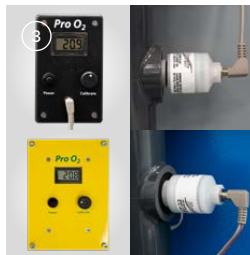

Nitrox line

LP Rotary Silent 300



Oxygen percentage

32% O₂

36% O₂

40% O₂

L/min.

600 l/min

400 l/min

300 l/min

Membrane type

Permea 230

LP Rotary Silent 300

It consists of an industrial screw compressor that delivers air at a pressure of 12 bar to a membrane that separates nitrogen and oxygen up to a maximum percentage of 40% oxygen. The enriched air can be compressed to 232 bar in combination with a high pressure compressor. The percentage of oxygen obtained at the outlet can be adjusted from 22.4% to 40% thanks to a valve accessible directly on the top of the compressor. The oxygen analyzer allows to verify the correct percentage, adjusting it through the appropriate valve.

Standard equipment

1 Electrical panel

2 Automatic condensate drain

3 2 Analyzers

4 Thermostat

5 1 Permea 230 membrane

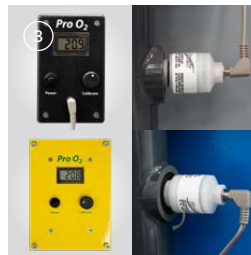

Nitrox line

LP Rotary Silent 600



Oxygen percentage

32% O₂

40% O₂

L/min.

1.000 l/min

600 l/min

Membrane type

Double Permea 230

LP Rotary Silent 600

It consists of an industrial screw compressor that delivers air at a pressure of 12 bar to a membrane that separates nitrogen and oxygen up to a maximum percentage of 40% oxygen. The enriched air can be compressed to 232 bar in combination with a high pressure compressor. The percentage of oxygen obtained at the outlet can be adjusted from 22.4% to 40% thanks to a valve accessible directly on the top of the compressor. The oxygen analyzer allows to verify the correct percentage, adjusting it through the appropriate valve.

Standard equipment

- | | | | |
|---|----------------------------|---|----------------------------|
| 1 | Electrical panel | 4 | Thermostat |
| 2 | Automatic condensate drain | 5 | Double Membrane Permea 230 |
| 3 | 2 Analyzers | | |



Fill containment cabinet

Armor



Armor 2

Armor 4

Filling connection

DIN 300 bar

DIN 300 bar

Contained cylinder

Max Diameter **220** mm

Any **Scuba**
or **SCBA** cylinder

Dimensions

60 x 73 x 104 cm

(W x D x H)

70 x 65 x 80 x 116 cm

(W x D x H1 x H2)

Armor 2

Coltri explosion-proof booths allow you to use the charging stations in total safety thanks to the taps, integrated hoses and pressure gauge.

Armor 4

The version for multiple refills with hinged door is equipped not only with the standard equipment, but also with filling valves and pressure management.



Standard equipment

-
- 1 Filling hose DIN 300 bar
-



Optional

-
- 1 Filling connection DRV DIN 232
2 Filling connection DRV DIN 300
-

-
- 3 DIN/INT adapter
4 Filling connection INT/YOKE
-



Aerotecnica Coltri S.p.A.

Via dei Colli Storici, 177
25015 Desenzano del Garda
Brescia - Italy

Tel. +39 030 9910301
+39 030 9910297

info@coltri.com



Visit our
showroom in
Virtual Reality



coltri.com



coltri.com/showroom



COLTRI | **60** YEARS OF COMPRESSOR HISTORY